

CONTENIDO

MOTOR

Fig. 1 CILINDRO Y CULATA.....	B2
Fig. 2 GIGÜEÑAL. PISTÓN.....	B3
Fig. 3 BOMBA DE AGUA.....	B4
Fig. 4 RADIADOR.....	B5
Fig. 5 BOMBA DE ACEITE.....	B6
Fig. 6 ADMISIÓN.....	B7
Fig. 7 CARBURADOR.....	B8-B9
Fig. 8 TUBO DE ESCAPE.....	B10
Fig. 9 CÁRTER.....	B11
Fig. 10 CUBIERTA DE CÁRTER 1.....	B12
Fig. 11 EMBRAGUE.....	B13
Fig. 12 TRANSMISIÓN.....	B14
Fig. 13 ENGR. DE TACÓMETRO.....	B15
Fig. 14 LEVA DE CAMBIO. HORQ.....	C2
Fig. 15 EJE DE CAMBIO. PEDAL.....	C3

CHASSIS

Fig. 16 BASTIDOR.....	C4
Fig. 17 GUARDABARROS.....	C5
Fig. 18 CUBIERTA LATERAL.....	C6-C7
Fig. 19 BRAZO TRASERO.....	C8
Fig. 20 DIRECCIÓN.....	C9
Fig. 21 HORQUILLA DELANTERA.....	C10-C-11
Fig. 22 DEPÓSITO DE COMBUSTIBLE.....	C12-C-13
Fig. 23 ASIENTO.....	C14
Fig. 24 RUEDA DELANTERA.....	C15

Fig. 25 PINZA FRENO DELANTERO.....	D2
Fig. 26 RUEDA TRASERA.....	D3-D4
Fig. 27 PINZA FRENO TRASERO.....	D5
Fig. 28 MANILLAR Y CABLES.....	D6
Fig. 29 BOMBA DE FRENO DELANTERO.....	D7
Fig. 30 ESTRIBERAS Y CABALLETE.....	D8-D9
Fig. 31 CILINDRO MAESTRO TRASERO.....	D10
Fig. 32 CÚPULA CARENADO.....	D11
Fig. 33 CARENADO.....	D12-D13
Fig. 34 GENERADOR.....	D14
Fig. 35 INTERMITENTES.....	D15
Fig. 36 PANEL DE C.KMS. Y TESTIGOS.....	E2
Fig. 37 FARO DELANTERO.....	E3
Fig. 38 PILOTO TRASERO.....	E4
Fig. 39 CONMUTADORES Y MANETAS.....	E5
Fig. 40 GRUPO ELÉCTRICO 1.....	E6-E7

ÍNDICE

ÍNDICE NUMÉRICO.....	M1 ~ M3
----------------------	---------



CATALOGO DE REPUESTOS

**TZR50 '01 Checa (4YV4)
ESPAÑA**

214YV-352S1

PRÓLOGOS

Este Catálogo de Repuestos corresponde a las piezas para el(los) modelo(s) del recuadro siguiente. Al formular el pedido de repuestos, se ruega citar este Catálogo de Repuestos y especificar correctamente los números de parte y los nombres de parte.

TZR50'01 Checa (4YV4)

1. Las modificaciones y agregados que se hayan realizado después de la edición de este Catálogo de Repuestos, serán anunciados en las informaciones de Recambios Yamaha.

2. Abreviaciones

En este Catálogo de Repuestos se emplean las siguientes abreviaciones:

- "UR" Usar el número de partes especificado
- "UN" Usar la cantidad necesaria
- "AP" Piezas sustitutivas
- "LM" Fabricación local (Partes necesarias que se pedirán localmente)
- "F#" No. de bastidor aplicable

3. Las piezas suministradas como conjunto se describen con un punto (•) que precede al nombre de la pieza como se indica a continuación.

EJEMPLO

CONJUNTO CARBURADOR

- INYECTOR, piloto
- BOQUILLA, principal

4. Cantidad de componentes de un conjunto.

La numeración que aparece a la derecha de cada descripción, indica la cantidad de piezas por cada unidad de conjunto.

EJEMPLO

CODIGO N.º	DESCRIPCIÓN	CANT.	OBSERVACIONES
2F5-83310-60	ENSAMBLAJE DE LA LUZ	1	
115-83311-60	• BOMBILLA, (6V-18W)	1	
1M1-83309-60	• REFLECTOR	1	

5. Los colores de los componentes se indican como sigue en la columna de "OBSERVACIONES".

EJEMPLO

CODIGO N.º	DESCRIPCIÓN	CANT.	OBSERVACIONES
2N4-24110-00-X5	COMP. DEL TANQUE	1	ROJO MAXIM
3J1-24240-10	• GRAFICO, JUEGO DEL TANQUE	1	para MXR

6. Números de Serie (A)

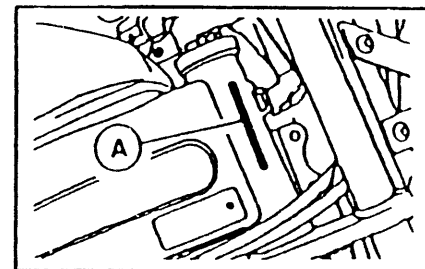

7. Debe tenerse en cuenta que las ilustraciones sirven como guía para la búsqueda de las referencias y no deben usarse para el montaje. Durante el montaje, se recomienda usar el manual de Taller correspondiente.

8. El asterisco (*) antes del número de referencia indica los elementos modificados después de la primera edición.

ETIQUETA DE MODELO

1. La etiqueta de Modelo está ubicada según indicación apartado (3).
 Cuando se utilice el Catálogo de Repuestos, se ruega que comparen el "Código de Modelo-Código de Producción" del Catálogo de Repuestos y el "Código de Modelo-Código de Producción" indicado en la Etiqueta de Modelo fijado en el producto correspondiente.

2. Indicación de la "Etiqueta de Modelo"

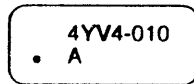
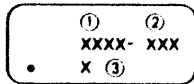

- ① Código de Modelo
- ② Código de Producción
- ③ Tipo de Color

3. Ubicación de la Etiqueta de Modelo

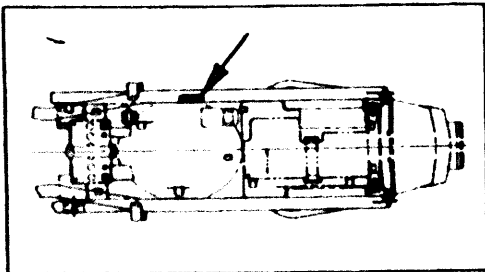

4. Información de Código de Modelo-Código de Producción del (los) modelo(s) indicado(s) en el Catálogo de Repuestos.

Código de Modelo	Código de Producción	País (destino)	Código de Modelo	Código de Producción	País (destino)
4YV4	000	ESPAÑA			

5. Información de Color

Código de Modelo	Código de tipo de color	Código de color	Nombre de Color	Abreviatura
4YV4	A	OQTR	ROMANTIQUE ROUGE	RTR

CONTENIDO

MOTOR

Fig. 1 CILINDRO Y CULATA.....	B2
Fig. 2 GIGÜEÑAL. PISTÓN	B3
Fig. 3 BOMBA DE AGUA	B4
Fig. 4 RADIADOR	B5
Fig. 5 BOMBA DE ACEITE	B6
Fig. 6 ADMISIÓN	B7
Fig. 7 CARBURADOR	B8-B9
Fig. 8 TUBO DE ESCAPE.....	B10
Fig. 9 CÁRTER	B11
Fig. 10 CUBIERTA DE CÁRTER 1	B12
Fig. 11 EMBRAGUE	B13
Fig. 12 TRANSMISIÓN.....	B14
Fig. 13 ENGR. DE TACÓMETRO	B15
Fig. 14 LEVA DE CAMBIO. HORQ.	C2
Fig. 15 EJE DE CAMBIO. PEDAL.....	C3

CHASSIS

Fig. 16 BASTIDOR	C4
Fig. 17 GUARDABARROS.....	C5
Fig. 18 CUBIERTA LATERAL.....	C6-C7
Fig. 19 BRAZO TRASERO.....	C8
Fig. 20 DIRECCIÓN	C9
Fig. 21 HORQUILLA DELANTERA	C10-C-11
Fig. 22 DEPÓSITO DE COMBUSTIBLE	C12-C-13
Fig. 23 ASIENTO	C14
Fig. 24 RUEDA DELANTERA	C15

Fig. 25 PINZA FRENO DELANTERO.....	D2
Fig. 26 RUEDA TRASERA	D3-D4
Fig. 27 PINZA FRENO TRASERO	D5
Fig. 28 MANILLAR Y CABLES	D6
Fig. 29 BOMBA DE FRENO DELANTERO	D7
Fig. 30 ESTRIBERAS Y CABALLETE.....	D8-D9
Fig. 31 CILINDRO MAESTRO TRASERO.....	D10
Fig. 32 CÚPULA CARENADO	D11
Fig. 33 CARENADO	D12-D13
Fig. 34 GENERADOR.....	D14
Fig. 35 INTERMITENTES.....	D15
Fig. 36 PANEL DE C.KMS. Y TESTIGOS.....	E2
Fig. 37 FARO DELANTERO.....	E3
Fig. 38 PILOTO TRASERO.....	E4
Fig. 39 CONMUTADORES Y MANETAS	E5
Fig. 40 GRUPO ELÉCTRICO 1.....	E6-E7

ÍNDICE

ÍNDICE NUMÉRICO	M1 ~ M3
-----------------------	---------

CONTENIDO

MOTOR

Fig. 1 CILINDRO Y CULATA.....	B2
Fig. 2 GIGÜEÑAL. PISTÓN.....	B3
Fig. 3 BOMBA DE AGUA.....	B4
Fig. 4 RADIADOR.....	B5
Fig. 5 BOMBA DE ACEITE.....	B6
Fig. 6 ADMISIÓN.....	B7
Fig. 7 CARBURADOR.....	B8-B9
Fig. 8 TUBO DE ESCAPE.....	B10
Fig. 9 CÁRTER.....	B11
Fig. 10 CUBIERTA DE CÁRTER 1.....	B12
Fig. 11 EMBRAGUE.....	B13
Fig. 12 TRANSMISIÓN.....	B14
Fig. 13 ENGR. DE TACÓMETRO.....	B15
Fig. 14 LEVA DE CAMBIO. HORQ.....	C2
Fig. 15 EJE DE CAMBIO. PEDAL.....	C3

CHASSIS

Fig. 16 BASTIDOR.....	C4
Fig. 17 GUARDABARROS.....	C5
Fig. 18 CUBIERTA LATERAL.....	C6-C7
Fig. 19 BRAZO TRASERO.....	C8
Fig. 20 DIRECCIÓN.....	C9
Fig. 21 HORQUILLA DELANTERA.....	C10-C-11
Fig. 22 DEPÓSITO DE COMBUSTIBLE.....	C12-C-13
Fig. 23 ASIENTO.....	C14
Fig. 24 RUEDA DELANTERA.....	C15

Fig. 25 PINZA FRENO DELANTERO.....	D2
Fig. 26 RUEDA TRASERA.....	D3-D4
Fig. 27 PINZA FRENO TRASERO.....	D5
Fig. 28 MANILLAR Y CABLES.....	D6
Fig. 29 BOMBA DE FRENO DELANTERO.....	D7
Fig. 30 ESTRIBERAS Y CABALLETE.....	D8-D9
Fig. 31 CILINDRO MAESTRO TRASERO.....	D10
Fig. 32 CÚPULA CARENADO.....	D11
Fig. 33 CARENADO.....	D12-D13
Fig. 34 GENERADOR.....	D14
Fig. 35 INTERMITENTES.....	D15
Fig. 36 PANEL DE C.KMS. Y TESTIGOS.....	E2
Fig. 37 FARO DELANTERO.....	E3
Fig. 38 PILOTO TRASERO.....	E4
Fig. 39 CONMUTADORES Y MANETAS.....	E5
Fig. 40 GRUPO ELÉCTRICO 1.....	E6-E7

ÍNDICE

ÍNDICE NUMÉRICO.....	M1 - M3
----------------------	---------

FIG. 1 - CILINDRO. CULATA

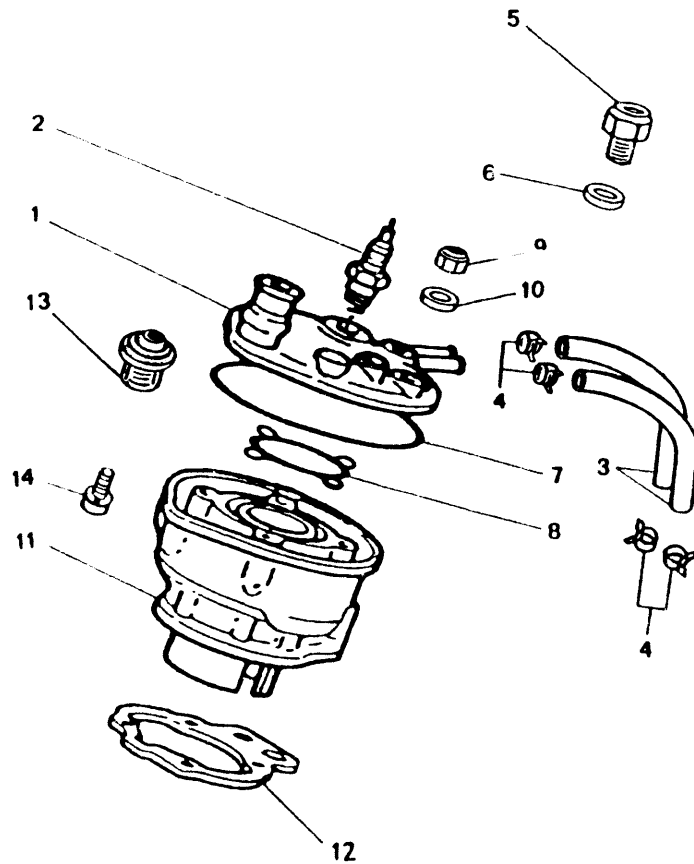

REF. N.º	CODIGO N.º	DESCRIPCION	CANT.	OBSERVACION
1	4YV-E1111-30	CULATA CILINDRO 1	1	
2	94701-00X00	BUJIA (NGK BR8ES)	1	
3	4YV-E2482-00	TUBO 2	2	
4	4YV-E2486-00	PRESILLA	4	
5	4YV-E2572-00	ADAPTADOR SENSOR	1	
6	90430-14822	JUNTA	1	
7	4YV-E1194-00	ANILLO O	1	
8	4YV-E1193-00	ANILLO O	1	
9	90176-07813	TUERCA CORONA	4	
10	90201-078L0	ARANDELA PLANA	4	
11	4YV-E1311-10	CILINDRO 1	1	
12	4YV-E1351-00	JUNTA DE CILINDRO	1	
13	4YV-E2411-00	TAPA	1	
14	98907-04010	TORNILLO CON ARANDELA	2	



4YV2352-0011

FIG. 2 - CIGÜEÑAL. PISTON

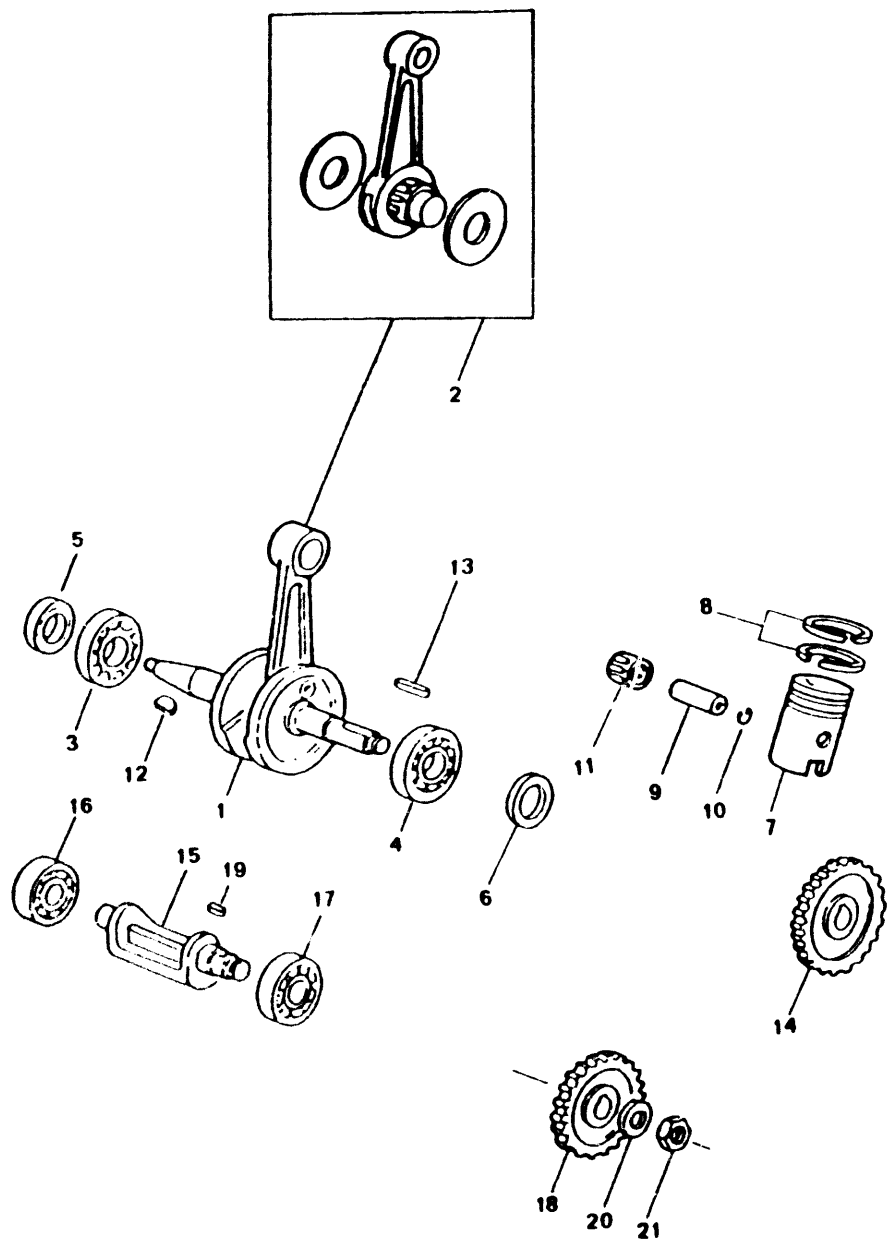

REF. N.º	CODIGO N.º	DESCRIPCION	CANT.	OBSERVACION
1	4YV-E1400-00	CIGÜEÑAL COMPLETO	1	
2	4YV-E1651-00	BIELA	1	
3	93306-303Y7	COJINETE	1	
4	93306-303Y7	COJINETE	1	
5	93101-17832	RETÉN ACEITE	1	
6	93101-24835	RETÉN ACEITE	1	
7	4YV-E1631-00	PISTÓN (ESTD)	1	UR STD
	4YV-E1635-00	PISTÓN (0.25 MM O/S)	1	AP
	4YV-E1636-00	PISTÓN (0.50 MM O/S)	1	AP
8	4YV-E1603-00	JUEGO DE AROS (ESTD)	1	UR STD
	4YV-E1604-00	JUEGO DE AROS (0.25 MM O/S)	1	AP
	4YV-E1605-00	JUEGO DE AROS (0.50 MM O/S)	1	AP
9	4YV-E1633-00	BULÓN PISTÓN	1	
10	93450-12816	PRESILLA REDONDA	2	
11	93310-112X5	COJINETE	1	
12	90280-03805	CHAVETA WOODRUFF	1	
13	90282-04806	CHAVETA RECTA	1	
14	4YV-E1536-00	ENGRANAJE TRACCIÓN	1	
15	4YV-E1454-00	PESO 1	1	
16	93306-202X2	COJINETE	1	
17	93306-203X6	COJINETE	1	
18	4YV-E1531-00	ENGRANAJE CONTRAPESO	1	
19	90282-04807	CHAVETA RECTA	1	
20	90201-128L1	ARANDELA PLANA	1	
21	90170-12853	TUERCA	1	



4YV2352-0020

FIG. 3 - BOMBA DE AGUA

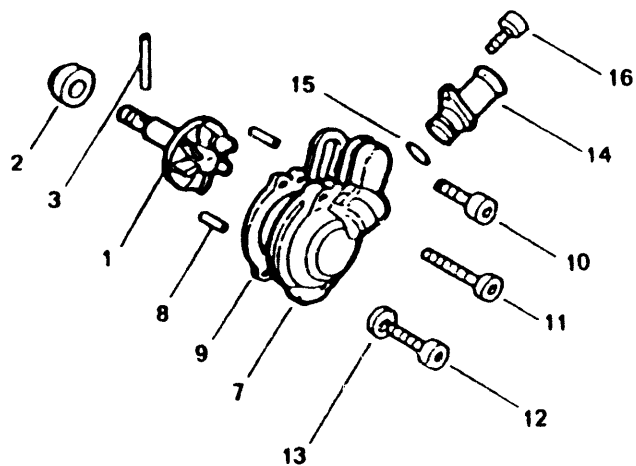
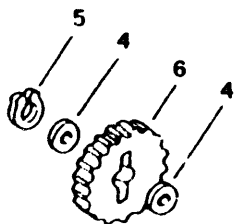

REF. N.º	CODIGO N.º	DESCRIPCION	CANT.	OBSERVACION
1	2VR-E2450-00	EJE DE IMPULSOR COMPLETO	1	
2	93103-10812	RETEN ACEITE	1	
3	93603-22028	PASADOR DE CLAVIJA	1	
4	90201-08512	ARANDELA PLANA	2	
5	93410-08130	PRESILLA REDONDA TIPO S	1	
6	3NC-E2459-00	ENGRANAJE EJE DE IMPULSOR	1	
7	3NC-E2422-00	CUBIERTA DE CAJA	1	
8	93604-10X00	PASADOR DE CLAVIJA	2	
9	3NC-E2428-01	EMPAQUE DE TAPA	1	
10	90110-06X23	TORNILLO ALLEN	1	
11	9131N-06055	TORNILLO ALLEN	1	
12	90110-06X04	TORNILLO ALOMADO CON (X)	1	
13	90201-06X09	JUNTA	1	
14	4YV-E2582-00	CONEXION	1	
15	93210-12327	ANILLO O	1	
16	9131N-06012	TORNILLO ALLEN	1	



4YV2352-003U

FIG. 4 - RADIADOR

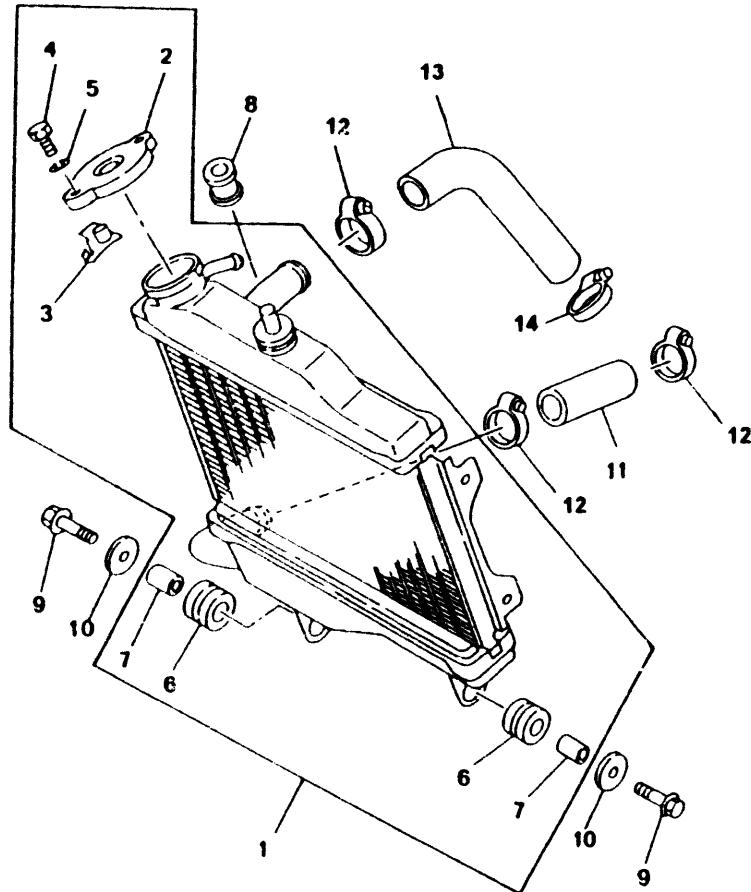

FWD

4YV2352-0040

REF. N.º	CODIGO N.º	DESCRIPCION	CANT.	OBSERVACION
1	4BA-E2460-00	RADIADOR COMPLETO	1	
2	2RN-E2462-00	• TAPA DE RADIADOR	1	
3	2RN-E2437-00	• TOPE	1	
4	9700M-05012	• TORNILLO HEXAGONAL	1	
5	9290M-05100	• ARANDELA GROWER	1	
6	90480-15363	• TAPON PROTECTOR	2	
7	90387-07392	• CASQUILLO	2	
8	90480-16284	TAPON PROTECTOR	1	
9	9580M-06025	TORNILLO HEXAGONAL CON VALONA	2	
10	90201-060A3	ARANDELA PLANA	2	
11	4YV-E2481-10	TUBO 1	1	
12	90450-25823	BRIDA DE MANGUERA	3	
13	4YV-E2483-00	TUBO 3	1	
14	90460-27815	BRIDA DE MANGUERA	1	

FIG. 5 - BOMBA DE ACEITE

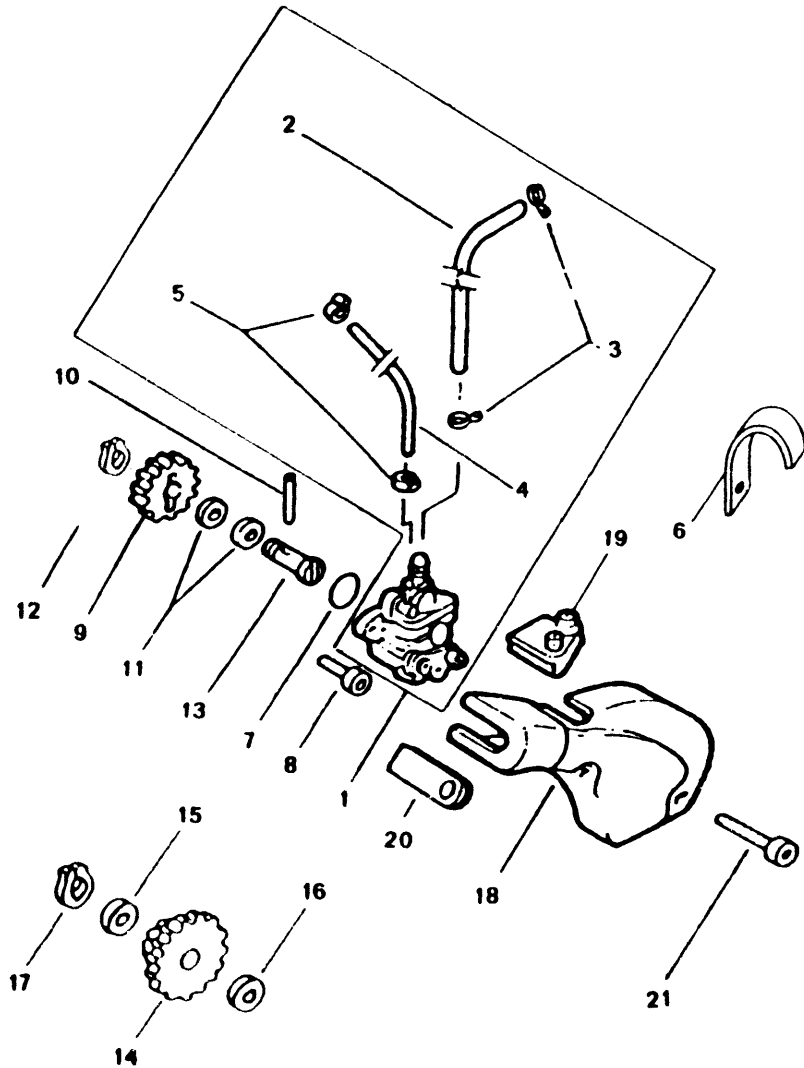

REF. N.º	CODIGO N.º	DESCRIPCION	CANT.	OBSERVACION
1	5BK-E3100-00	BOMBA DE ACEITE COMPLETA	1	
2	4YV-E316F-10	• MANGUERA, DE ACEITE 1	1	
3	93430-08036	• PRESILLA REDONDA TIPO E	2	
4	4YV-E316G-10	• MANGUERA, DE ACEITE 2	1	
5	90468-04817	• PRESILLA	2	
6	90465-08028	BRIDA	1	
7	90201-198L2	ARANDELA PLANA	1	
8	9131N-05016	TORNILLO ALLEN	2	
9	4YV-E3178-00	ENGRANAJE TRACC. DE BOMBA	1	
10	93603-22028	PASADOR DE CLAVIJA	1	
11	90201-088L3	ARANDELA PLANA	2	
12	93440-08130	PRESILLA REDONDA TIPO S	1	
13	4YV-E3226-00	EJE DE ENGRANAJES DE TRACCION	1	
14	4YV-E3179-00	ENGRANAJE PUNTO NEUTRO	1	
15	90201-088L3	ARANDELA PLANA	1	
16	90201-08512	ARANDELA PLANA	1	
17	93440-08130	PRESILLA REDONDA TIPO S	1	
18	4YV-E5416-00	TAPA DE BOMBA DE ACEITE	1	
19	4YV-E3174-00	SOSTEN TUBO DE ACEITE	1	
20	4YV-E5379-00	SELLO DE CARTER	1	
21	9131N-05035	TORNILLO ALLEN	2	



4YV2352-0050

FIG. 6 - ADMISION

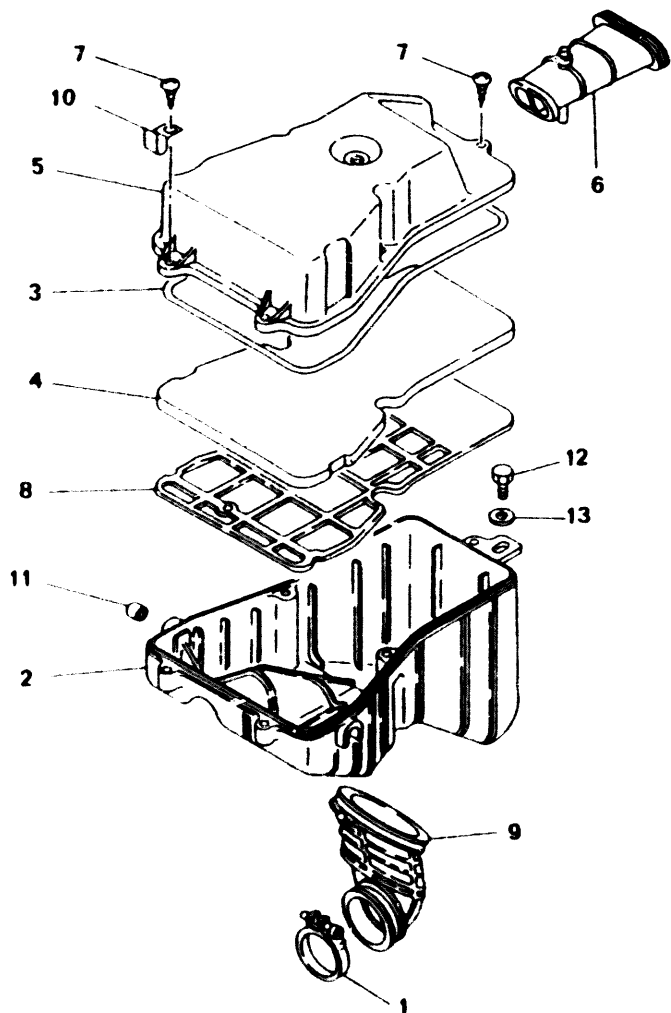

REF. N.º	CODIGO N.º	DESCRIPCION	CANT.	OBSERVACION
1	90467-24140	BRIDA DE MANGUERA	1	
2	2RN-E4411-00	CAJA FILTRO DE AIRE 1	1	
3	2RN-E4452-00	SELLO	1	
4	2RN-E4451-00	ELEMENTO DE FILTRO DE AIRE	1	
5	2RN-E4412-00	TAPA CAJA DE FILTRO 1	1	
6	4BA-E4437-00	CONDUCTO	1	
7	9770L-50525	TORNILLO PARA CHAPA ALOMADO	5	
8	4BA-E4472-00	PLACA DE ELEMENTO	1	
9	4YV-E4453-10	TOBERA DE UNION	1	
10	4BA-E4415-00	SOPORTE DE CABLE	1	
11	90445-12718	MANGUERA	2	
12	9700L-06016	TORNILLO HEXAGONAL	1	
13	90201-06008	ARANDELA PLANA	1	



4YV2352-0060

FIG. 7 - CARBURACION

REF. N.º	CODIGO N.º	DESCRIPCION	CANT.	OBSERVACION
1	4YV-E4101-10	CARBURADOR COMPLETO 1	1	
2	4SB-E4216-10	• TORNILLO	2	
3	5DU-E4369-00	• DIAFRAGMA COMPLETO 2	1	
4	5DU-E4392-00	• VALVULA DE AGUJA	1	
5	4SB-E4115-00	• TAPON TORNILLO	1	
6	4SB-E4325-00	• TORNILLO CABEZA REDONDA	1	
7	4SB-E4342-00	• SURTIDOR DE PILOTO	1	
8	5DU-E4343-00	• INYECTOR PRINCIPAL	1	
9	5BV-E4341-00	• BOQUILLA PRINCIPAL	1	
10	5AD-E4336-00	• AGUJA DEL SURTIDOR	1	
11	4SB-E4137-00	• PRESILLA	1	
12	4SB-E4377-00	• TOPE	1	
13	4SB-E4312-00	• VALVULA DE OBTURADOR 1	1	
14	4SB-E4331-00	• RESORTE VALVULA ACELERADOR	1	
15	5DU-E4344-00	• INYECTOR DE ARRANQUE	1	
16	4SB-E4371-00	• EMBOLO DE ARRANQUE	1	
17	4SB-E4335-00	• RESORTE DE EMBOLO	1	
18	5DU-E4368-00	• DIAFRAGMA COMPLETO 1	1	
19	5DU-E4396-00	• TUBO	1	
20	5DU-E4197-00	• TUBO	1	
21	4SB-E4216-00	• TORNILLO	1	
22	4SB-E4104-00	• TORNILLO DE AIRE	1	
23	4SB-E4134-00	• RESORTE AJUSTE DE VALVULA	1	
24	4SB-E4103-00	• JUEGO DE TORNILLO, ACELERADOR	1	
25	4SB-E4133-00	• RESORTE TOPE DE ACELERACION	1	
26	4SB-E4385-00	• BOIA	1	
27	4SB-E4386-00	• PASADOR DE BOIA	1	

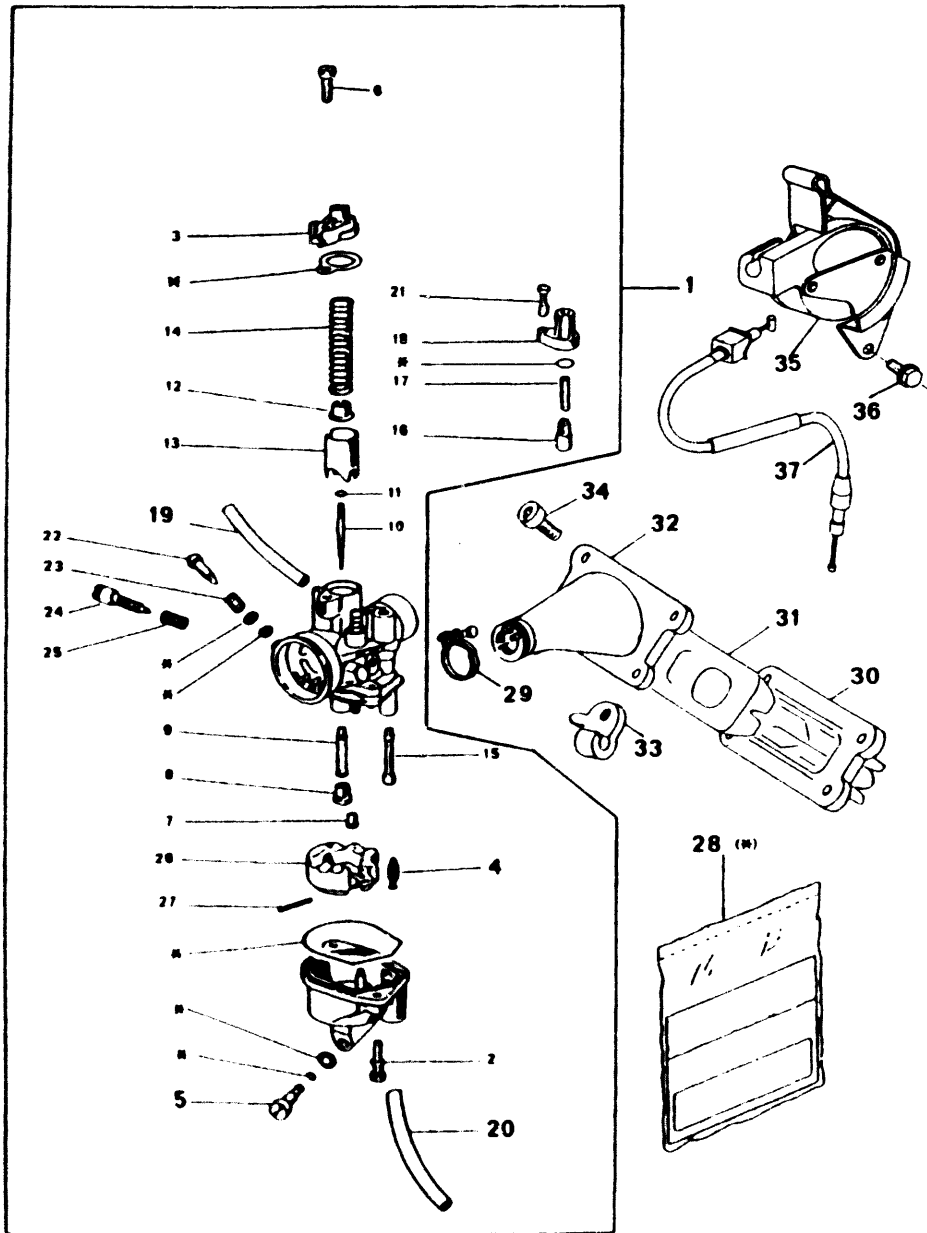

4YV2352-0070

FIG. 7 - CARBURACION

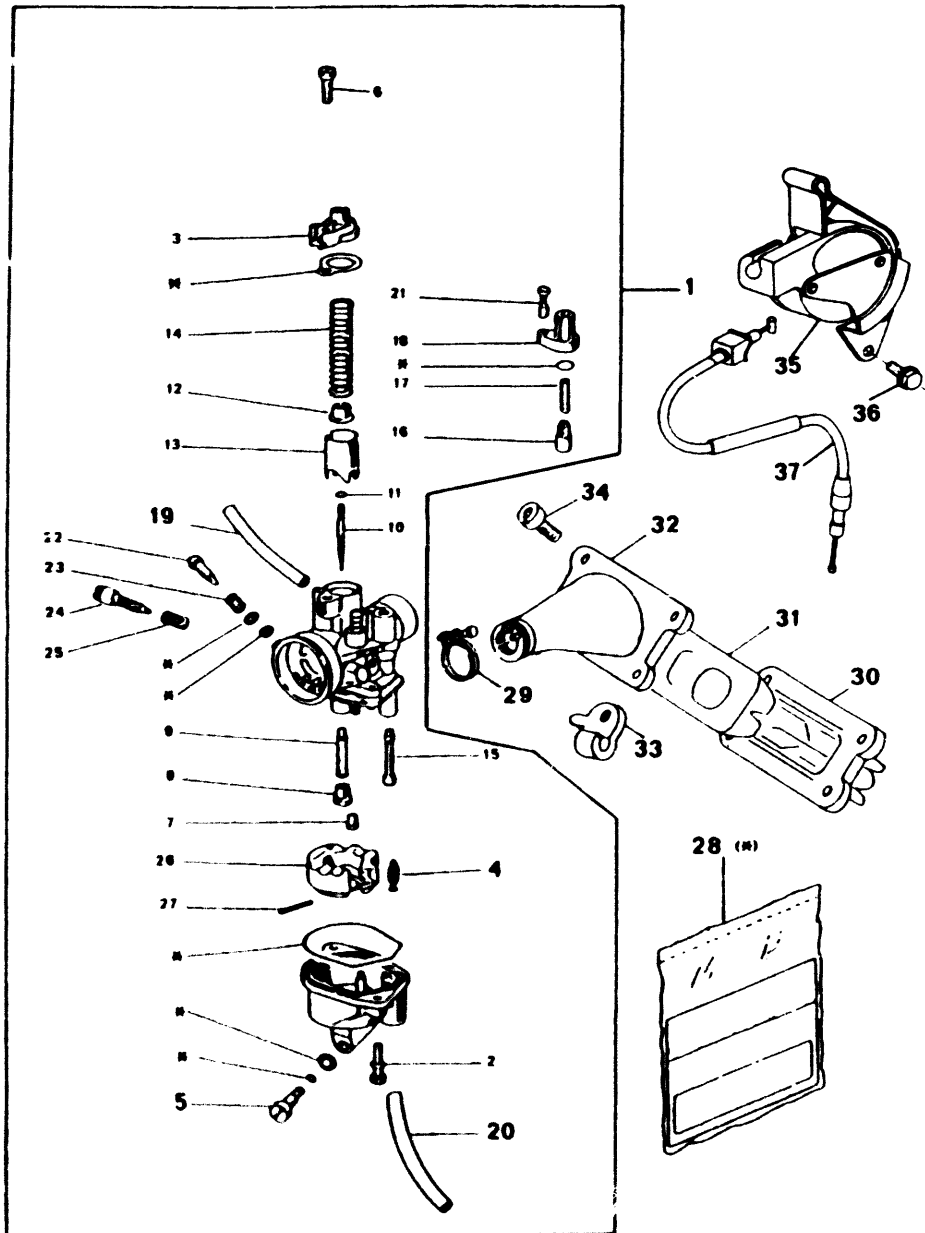

REF. N.º	CODIGO N.º	DESCRIPCION	CANT.	OBSERVACION
28	4SB-W0001-00	• JUEGO DE JUNTAS	1	
29	90450-32X00	ABRAZADERA CARBURADOR	1	
30	4YV-E3610-00	VALVULA DE LENGUETA COMPLETA	1	
31	4YV-E3625-00	ESPACIADOR VALVULA LENGUETA	1	
32	4YV-E3565-10	UNION DE CARBURADOR	1	
33	4YV-E5441-00	SOSTEN DE CABLE DE EMBRAGUE	1	
34	9131L-06020	TORNILLO ALLEN	4	
35	3TJ-83940-02	STARTER COMPLETO	1	
36	9580L-06010	TORNILLO HEX. CON VALONA	1	
37	4YV-F6331-00	CABLE STARTER	1	



4YV2352-0070

FIG. 8 - TUBO DE ESCAPE

REF. N.º	CODIGO N.º	DESCRIPCION	CANT.	OBSERVACION
-------------	------------	-------------	-------	-------------

1	4YV-E4710-10	SILENCIADOR COMPLETO 1	1	
2	93210-288E2	ANILLO O	1	
3	90506-18856	RESORTE DE TENSION	2	
4	9570M-08500	TUERCA DE BRIDA	1	
5	9582M-08035	TORNILLO HEXAGONAL CON VALONA	2	
6	9290M-08600	ARANDELA PLANA	1	
7	90201-083F7	ARANDELA PLANA	1	

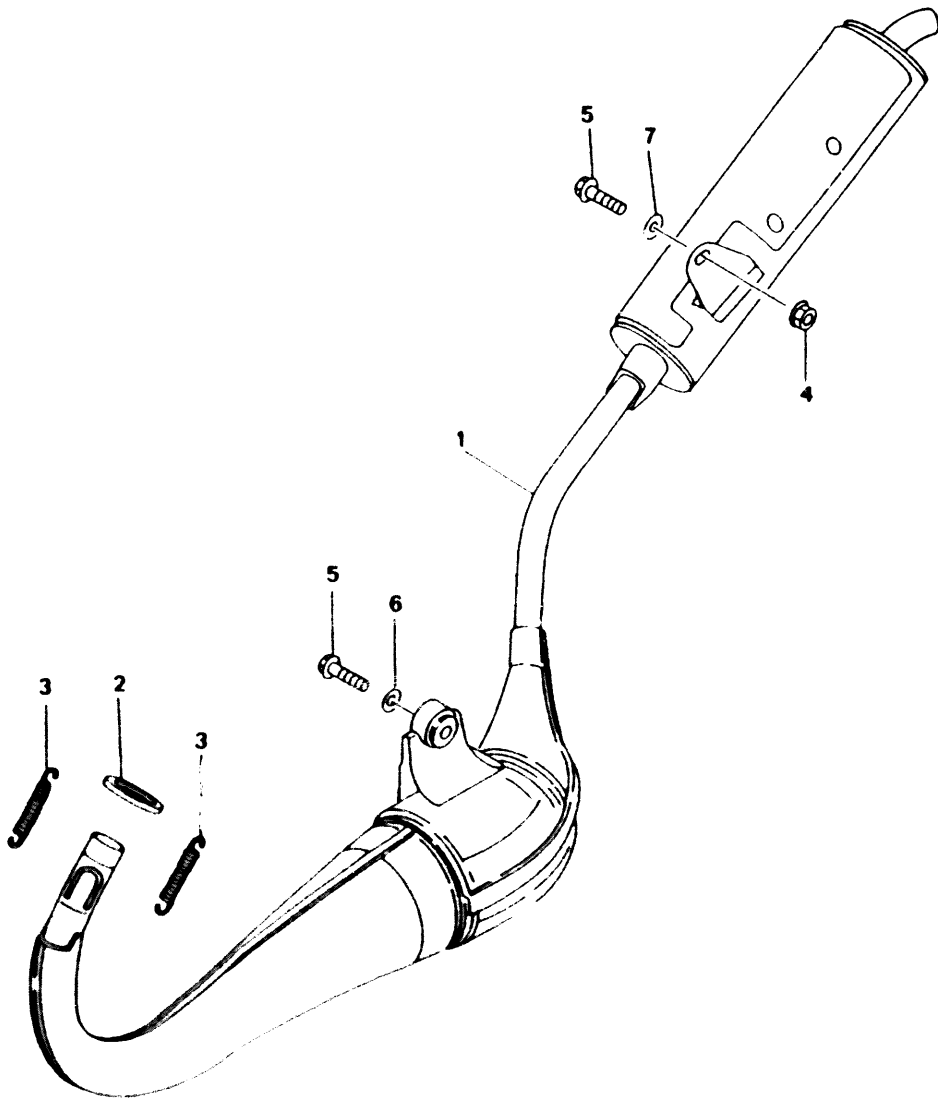

4YV2352-0080

FIG. 9 - CARTER

REF. N.º	CODIGO N.º	DESCRIPCION	CANT.	OBSERVACION
1	4YV-E5150-10	CARTER COMPLETO	1	
2	90116-07835	TORNILLO DE PUNTAL	4	
3	91812-12805	PASADOR DE CLAVIJA	2	
4	9131N-06040	TORNILLO ALLEN	13	
5	3FN-E5371-00	RESPIRADERO	1	
6	90445-05773	MANGUERA	1	
7	4YV-E5128-00	SOPORTE	1	
8	9131N-05012	TORNILLO ALLEN	1	
9	90101-08873	TORNILLO HEXAGONAL	1	
10	90201-08X01	JUNTA	1	
11	90101-12874	TORNILLO HEXAGONAL	1	
12	90430-12823	JUNTA	1	

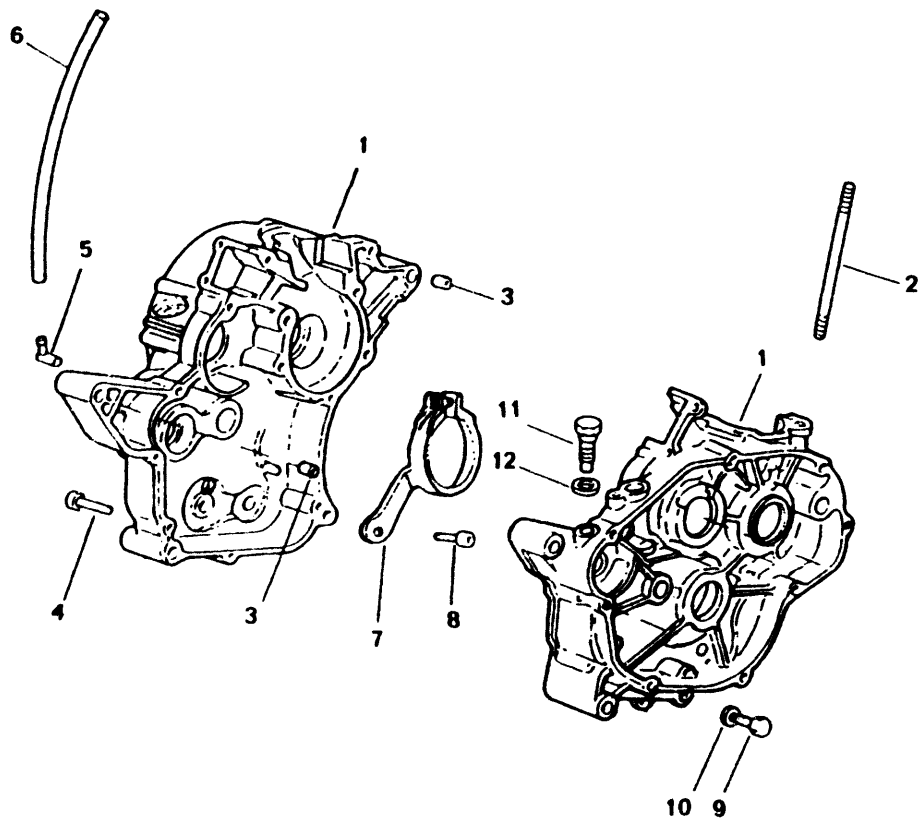

4YV2352-0090

FIG. 10 - CUBIERTA DE CARTER 1

REF. N.º	CODIGO N.º	DESCRIPCION	CANT.	OBSERVACION
----------	------------	-------------	-------	-------------

1	4YV-E5411-00	TAPA DE CARTER 1	1	
2	9131N-05020	TORNILLO ALLEN	5	
3	4YV-E5451-00	JUNTA DE CUBIERTA DE CARTER	1	
4	4YV-E5421-00	TAPA DE CARTER 2	1	
5	4YV-E5461-00	JUNTA CUBIERTA DE CARTER 2	1	
6	91809-08806	PASADOR DE CLAVIJA	2	
7	90110-06X05	TORNILLO ALLEN	4	
8	4YV-E5363-00	TAPON DE ACEITE	1	
9	93210-128E3	ANILLO O	1	
10	90154-06812	TORNILLO DE LIGAR	1	
11	90430-06166	JUNTA	1	
12	4YV-E5378-00	SOPORTE	1	
13	90201-08X01	JUNTA	1	
14	4YV-E3228-00	REGULADOR DE ACEITE	1	
15	4YV-E5431-00	TAPA DE CARTER 3	1	
16	9131M-05014	TORNILLO ALLEN	2	
17	90387-058P0	CASQUILLO	2	

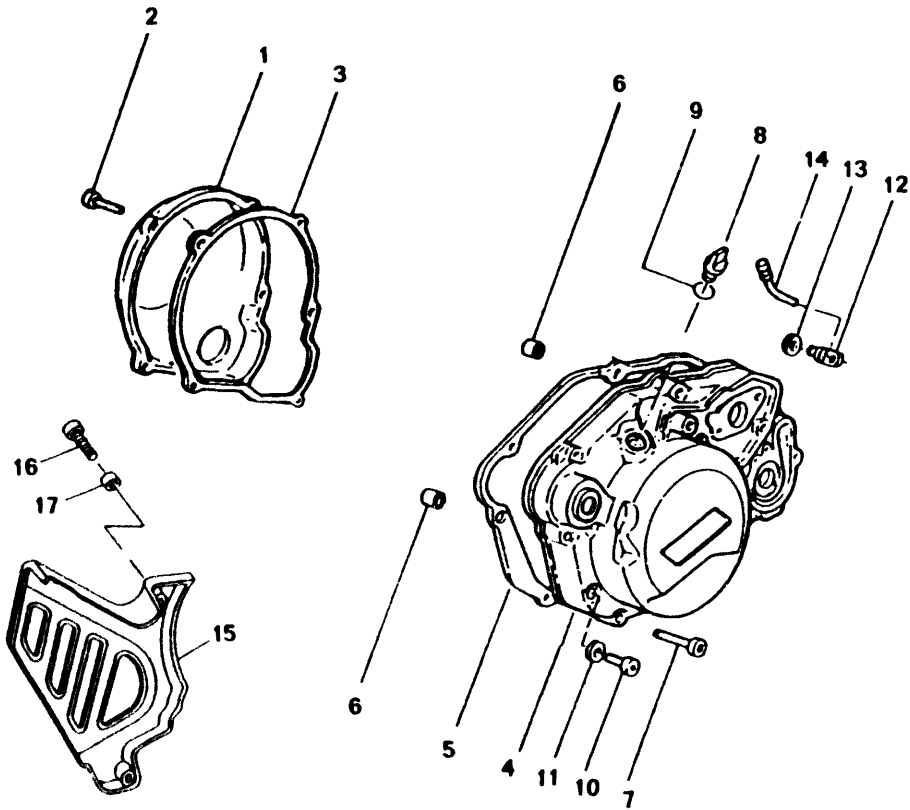

4YV2352-0100

FIG. 11 - EMBRAGUE

REF. N.º	CODIGO N.º	DESCRIPCION	CANT.	OBSERVACION
----------	------------	-------------	-------	-------------

1	4YV-E6111-00	ENGRANAJE TRACC. PRIMARIA	1	
2	90387-168P1	CASQUILLO	1	
3	93210-138E4	ANILLO O	1	
4	90179-12248	TUERCA	1	
5	4YV-E6150-00	ENGRANAJE TRACCION PRIM. COMPL.	1	
6	4YV-E6154-00	PLACA DE EMPUJE 1	1	
7	4YV-E6371-00	CUBO DE EMBRAGUE	1	
8	3NC-E6331-00	DISCO DE FRICCION 2	5	
9	2AH-E6324-00	PLACA DE EMBRAGUE	4	
10	4YV-E6351-00	PLATO DE PRESION 1	1	
11	90501-20859	RESORTE DE COMPRESION	4	
12	9131N-05020	TORNILLO ALLEN	4	
13	90201-058L4	ARANDELA PLANA	4	
14	4YV-E6164-00	PLACA DE EMPUJE 2	1	
15	90208-17807	ARANDELA DE RESORTE CONICO	1	
16	90170-12854	TUERCA	1	
17	90215-12271	ARANDELA DE CIERRE	1	
18	4YV-E6356-00	VARILLA DE EMPUJE 1	1	
19	90113-14804	TORNILLO JUEGO	1	
20	90170-14855	TUERCA	1	
21	93503-16003	BOLA	1	
22	4YV-E6357-00	VARILLA DE EMPUJE 2	1	
23	4YV-E6381-00	CONJ. PALANCA DE EMPUJE	1	
24	90508-20846	RESORTE DE TORSION	1	
25	90201-158L5	ARANDELA PLANA	1	
26	93101-15833	RETEN ACEITE	1	

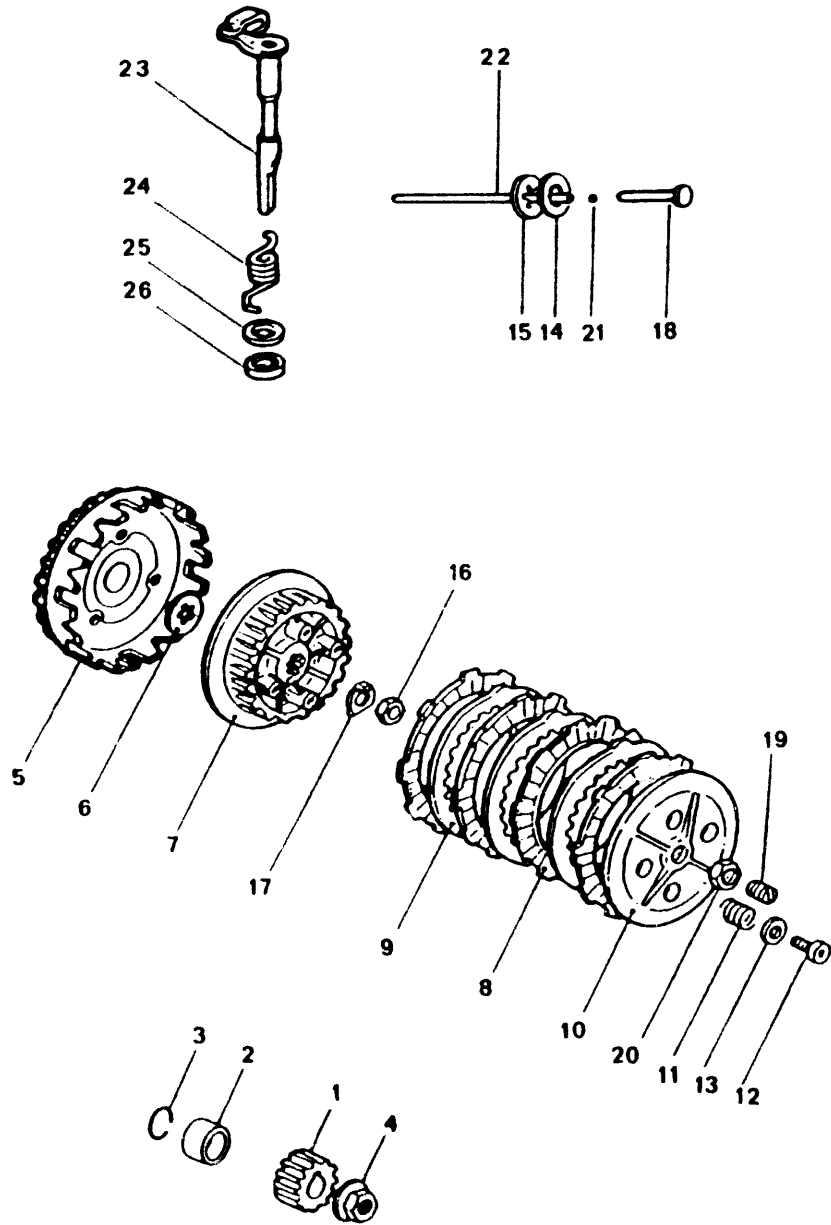

4YV2352-0110

FIG. 12 - TRANSMISION

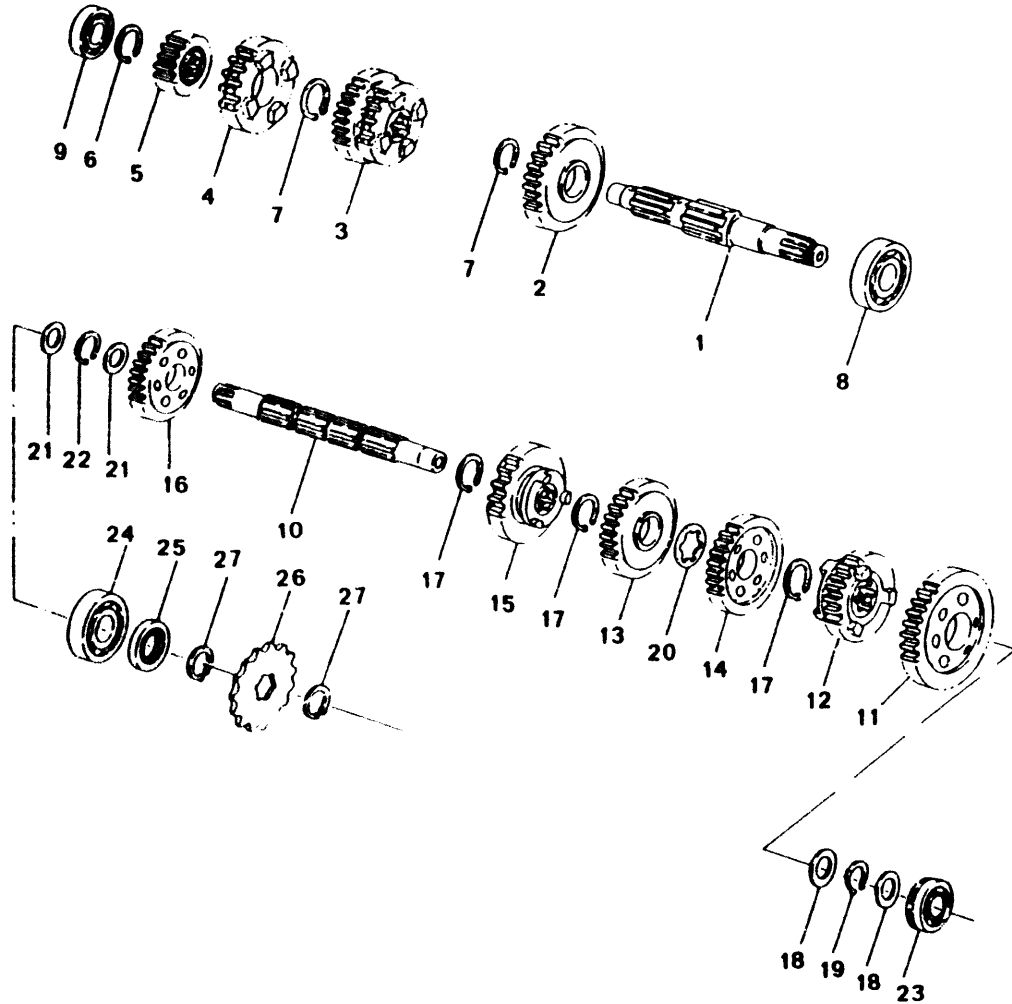

REF. N.º	CODIGO N.º	DESCRIPCION	CANT.	OBSERVACION
1	4YV-E7411-00	EJE PRINCIPAL	1	
2	4YV-E7151-00	ENGRANAJE PIÑON DE 5TA.	1	
3	4YV-E7131-00	ENGRANAJE PIÑON DE 3RA.	1	
4	4YV-E7161-00	ENGRANAJE PIÑON DE 6TA.	1	
5	4YV-E7121-00	ENGRANAJE PIÑON DE 2DA.	1	
6	93440-14815	PRESILLA REDONDA	1	
7	93440-18816	PRESILLA REDONDA	2	
8	93306-203YC	COJINETE	1	
9	93315-21429	COJINETE	1	
10	4YV-E7421-00	EJE DE TRACCION	1	
11	4YV-E7211-00	ENGRANAJE RUEDA DE 1RA.	1	
12	4YV-E7251-00	ENGRANAJE RUEDA DE 5TA.	1	
13	4YV-E7241-00	ENGRANAJE RUEDA DE 4TA.	1	
14	4YV-E7231-00	ENGRANAJE RUEDA DE 3RA.	1	
15	4YV-E7261-00	ENGRANAJE RUEDA DE 6TA.	1	
16	4YV-E7221-00	ENGRANAJE RUEDA DE 2DA.	1	
17	93440-20825	PRESILLA REDONDA	3	
18	90201-148L6	ARANDELA PLANA	2	
19	93410-14815	PRESILLA REDONDA TIPO S	1	
20	90201-208L7	ARANDELA PLANA	1	
21	90201-208L8	ARANDELA PLANA	2	
22	93410-20825	PRESILLA REDONDA TIPO S	1	
23	93315-21429	COJINETE	1	
24	93306-204X1	COJINETE	1	
25	93102-20873	RETEN ACEITE	1	
26	5BX-E7460-00	CORONA	1	
27	93410-20825	PRESILLA REDONDA TIPO S	2	



4YV2352-0120

FIG. 13 - ENGRANAJE DE TACOMETRO

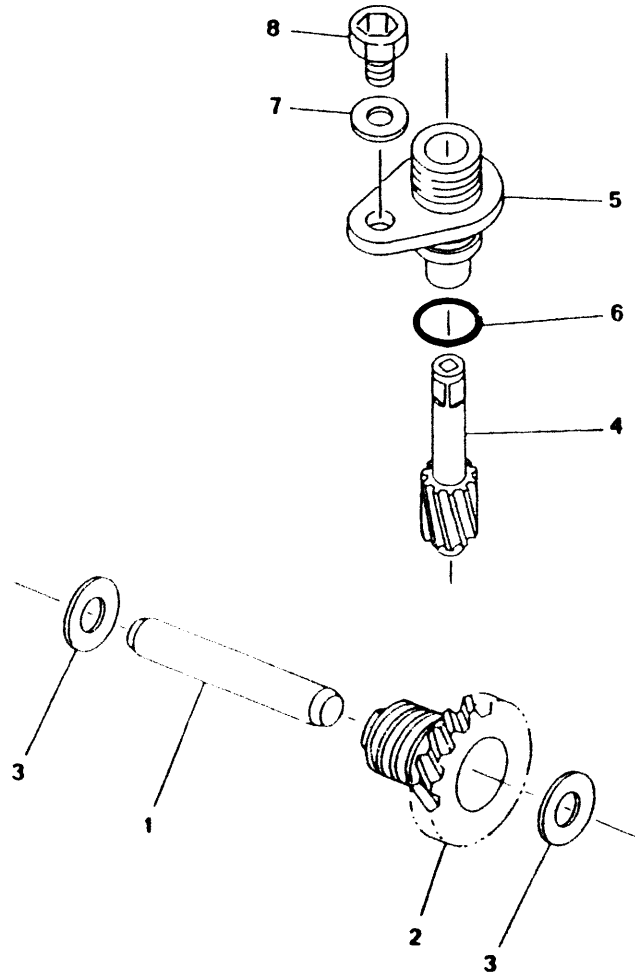

REF. N.º	CODIGO N.º	DESCRIPCION	CANT.	OBSERVACION
1	4YV-E7861-00	EJE DE ENGRANAJE DE TRACCION	1	
2	4YV-E7831-00	ENGRANAJE DE TRACCION	1	
3	90201-088L3	ARANDELA PLANA	2	
4	4YV-E7841-00	ENGRANAJE DE TRACCION	1	
5	3NC-E7811-00	CAJA ENGRANAJE TACOMETRO	1	
6	93210-12237	ANILLO O	1	
7	4L0-17818-00	EMPAQUE	1	
8	9131N-06012	TORNILLO ALLEN	1	



4YV2352-0130

CONTENIDO

MOTOR

Fig. 1 CILINDRO Y CULATA	B2
Fig. 2 GIGÜEÑAL. PISTÓN	B3
Fig. 3 BOMBA DE AGUA	B4
Fig. 4 RADIADOR	B5
Fig. 5 BOMBA DE ACEITE	B6
Fig. 6 ADMISIÓN	B7
Fig. 7 CARBURADOR	B8-B9
Fig. 8 TUBO DE ESCAPE	B10
Fig. 9 CÁRTER	B11
Fig. 10 CUBIERTA DE CÁRTER 1	B12
Fig. 11 EMBRAGUE	B13
Fig. 12 TRANSMISIÓN	B14
Fig. 13 ENGR. DE TACÓMETRO	B15
Fig. 14 LEVA DE CAMBIO. HORQ.	C2
Fig. 15 EJE DE CAMBIO. PEDAL	C3

CHASSIS

Fig. 16 BASTIDOR	C4
Fig. 17 GUARDABARROS	C5
Fig. 18 CUBIERTA LATERAL	C6-C7
Fig. 19 BRAZO TRASERO	C8
Fig. 20 DIRECCIÓN	C9
Fig. 21 HORQUILLA DELANTERA	C10-C-11
Fig. 22 DEPÓSITO DE COMBUSTIBLE	C12-C-13
Fig. 23 ASIENTO	C14
Fig. 24 RUEDA DELANTERA	C15

Fig. 25 PINZA FRENO DELANTERO	D2
Fig. 26 RUEDA TRASERA	D3-D4
Fig. 27 PINZA FRENO TRASERO	D5
Fig. 28 MANILLAR Y CABLES	D6
Fig. 29 BOMBA DE FRENO DELANTERO	D7
Fig. 30 ESTRIBERAS Y CABALLETE	D8-D9
Fig. 31 CILINDRO MAESTRO TRASERO	D10
Fig. 32 CÚPULA CARENADO	D11
Fig. 33 CARENADO	D12-D13
Fig. 34 GENERADOR	D14
Fig. 35 INTERMITENTES	D15
Fig. 36 PANEL DE C.KMS. Y TESTIGOS	E2
Fig. 37 FARO DELANTERO	E3
Fig. 38 PILOTO TRASERO	E4
Fig. 39 CONMUTADORES Y MANETAS	E5
Fig. 40 GRUPO ELÉCTRICO 1	E6-E7

ÍNDICE

ÍNDICE NUMÉRICO	M1 ~ M3
-----------------------	---------

CONTENIDO

MOTOR

Fig. 1 CILINDRO Y CULATA.....	B2
Fig. 2 GIGÜEÑAL. PISTÓN.....	B3
Fig. 3 BOMBA DE AGUA.....	B4
Fig. 4 RADIADOR.....	B5
Fig. 5 BOMBA DE ACEITE.....	B6
Fig. 6 ADMISIÓN.....	B7
Fig. 7 CARBURADOR.....	B8-B9
Fig. 8 TUBO DE ESCAPE.....	B10
Fig. 9 CÁRTER.....	B11
Fig. 10 CUBIERTA DE CÁRTER 1.....	B12
Fig. 11 EMBRAGUE.....	B13
Fig. 12 TRANSMISIÓN.....	B14
Fig. 13 ENGR. DE TACÓMETRO.....	B15
Fig. 14 LEVA DE CAMBIO. HORQ.....	C2
Fig. 15 EJE DE CAMBIO. PEDAL.....	C3

CHASSIS

Fig. 16 BASTIDOR.....	C4
Fig. 17 GUARDABARROS.....	C5
Fig. 18 CUBIERTA LATERAL.....	C6-C7
Fig. 19 BRAZO TRASERO.....	C8
Fig. 20 DIRECCIÓN.....	C9
Fig. 21 HORQUILLA DELANTERA.....	C10-C-11
Fig. 22 DEPÓSITO DE COMBUSTIBLE.....	C12-C-13
Fig. 23 ASIENTO.....	C14
Fig. 24 RUEDA DELANTERA.....	C15

Fig. 25 PINZA FRENO DELANTERO.....	D2
Fig. 26 RUEDA TRASERA.....	D3-D4
Fig. 27 PINZA FRENO TRASERO.....	D5
Fig. 28 MANILLAR Y CABLES.....	D6
Fig. 29 BOMBA DE FRENO DELANTERO.....	D7
Fig. 30 ESTRIBERAS Y CABALLETE.....	D8-D9
Fig. 31 CILINDRO MAESTRO TRASERO.....	D10
Fig. 32 CÚPULA CARENADO.....	D11
Fig. 33 CARENADO.....	D12-D13
Fig. 34 GENERADOR.....	D14
Fig. 35 INTERMITENTES.....	D15
Fig. 36 PANEL DE C.KMS. Y TESTIGOS.....	E2
Fig. 37 FARO DELANTERO.....	E3
Fig. 38 PILOTO TRASERO.....	E4
Fig. 39 CONMUTADORES Y MANETAS.....	E5
Fig. 40 GRUPO ELÉCTRICO 1.....	E6-E7

ÍNDICE

ÍNDICE NUMÉRICO.....	M1 ~ M3
----------------------	---------

FIG. 14 - LEVA DE CAMBIO. HORQUILLA

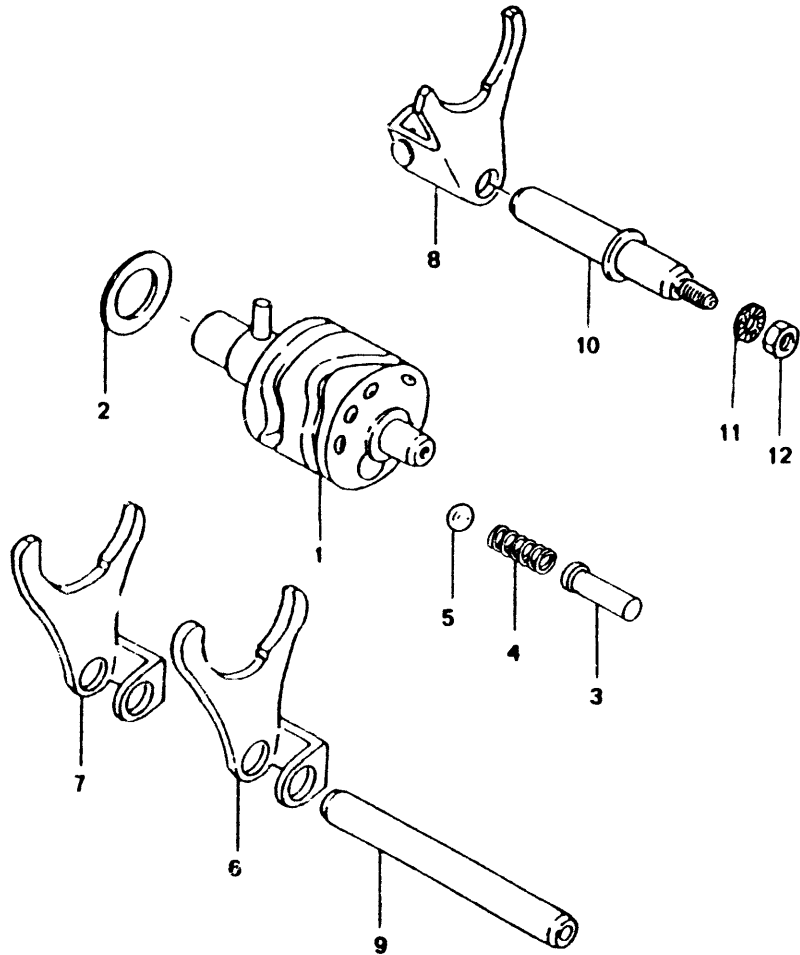

REF. N.º	CODIGO N.º	DESCRIPCION	CANT.	OBSERVACION
1	4YV-E8540-00	LEVA DE CAMBIO COMPLETO	1	
2	90201-108L9	ARANDELA PLANA	1	
3	4YV-E8542-00	PUNTO NEUTRO	1	
4	90501-12860	RESORTE DE COMPRESION	1	
5	93500-09827	BOLA	1	
6	4YV-E8511-00	HORQUILLA DE CAMBIO 1	1	
7	4YV-E8512-00	HORQUILLA DE CAMBIO 2	1	
8	4YV-E8513-00	HORQUILLA DE CAMBIO 3	1	
9	4YV-E8531-00	BARRA GUIA HORQ. CAMBIO 1	1	
10	4YV-E8535-00	BARRA GUIA HORQ. CAMBIO 2	1	
11	90205-07801	ARANDELA DENTADA	1	
12	90170-07856	TUERCA	1	



4YV2352-0140

FIG. 16 - BASTIDOR

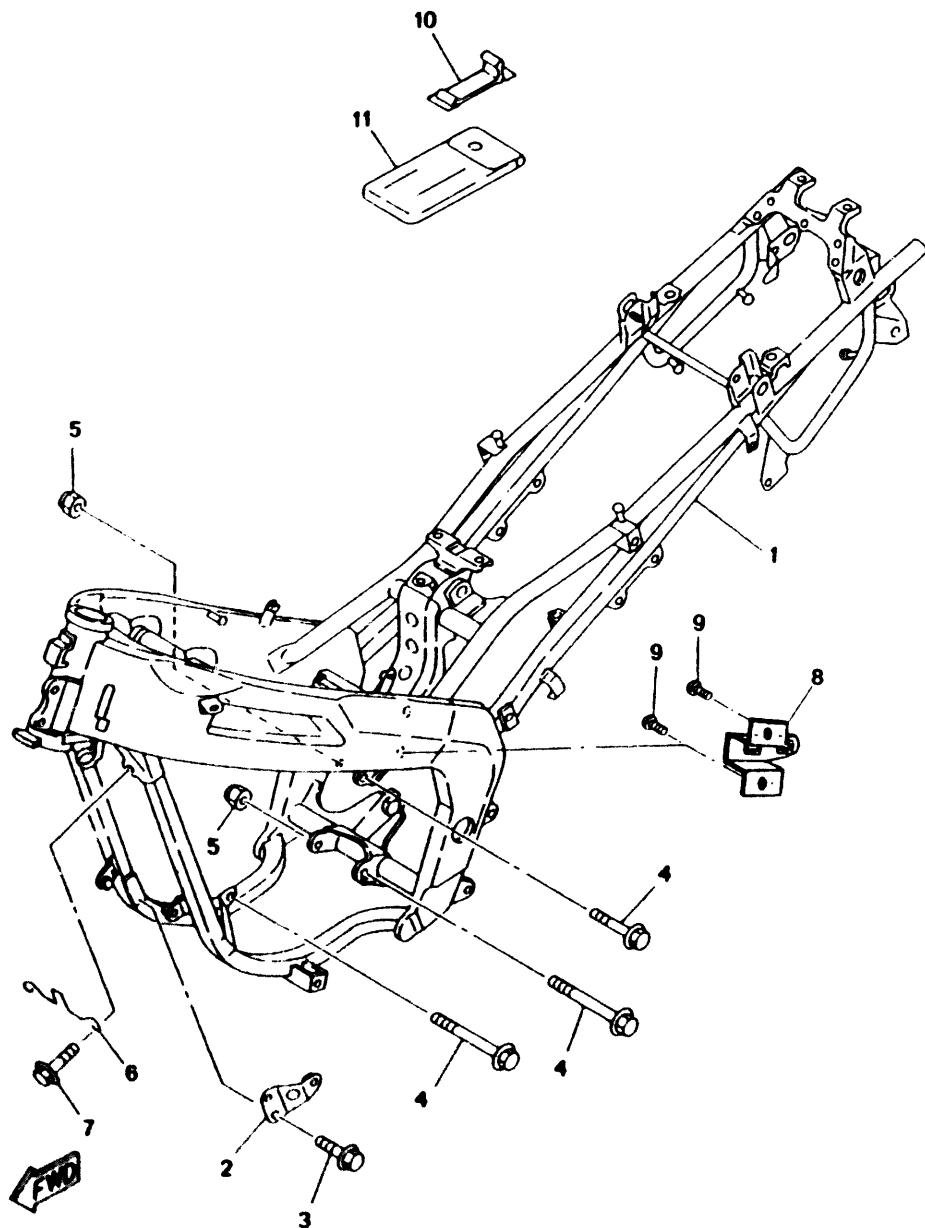

REF. N.º	CODIGO N.º	DESCRIPCION	CANT.	OBSERVACION
1	4YV-F1110-10-98	BASTIDOR COMPLETO	1	UR LOW GLOSS BLACK
2	4YV-F1418-00	SOPORTE INFERIOR DELANTERO 2	1	
3	9582M-08012	TORNILLO HEXAGONAL CON VALONA	2	
4	90105-08875	TORNILLO HEXAGONAL CON VALONA	3	
5	95607-08200	TUERCA DE AUTO-CIERRE	2	
6	4BA-F1288-00	GUIA DE CABLE	1	
7	9580M-06012	TORNILLO HEXAGONAL CON VALONA	2	
8	4YV-F1274-00	SOPORTE DE UNIDAD C.D.I.	1	
9	9760N-06212	TORNILLO ALOMADO CON ARANDELA	2	
10	21L-F8100-10	JUEGO DE HERRAMIENTAS	1	
11	1TK-H2131-00	BANDA DE BATERIA	1	

4YV2352-0160

FIG. 17 - GUARDABARROS

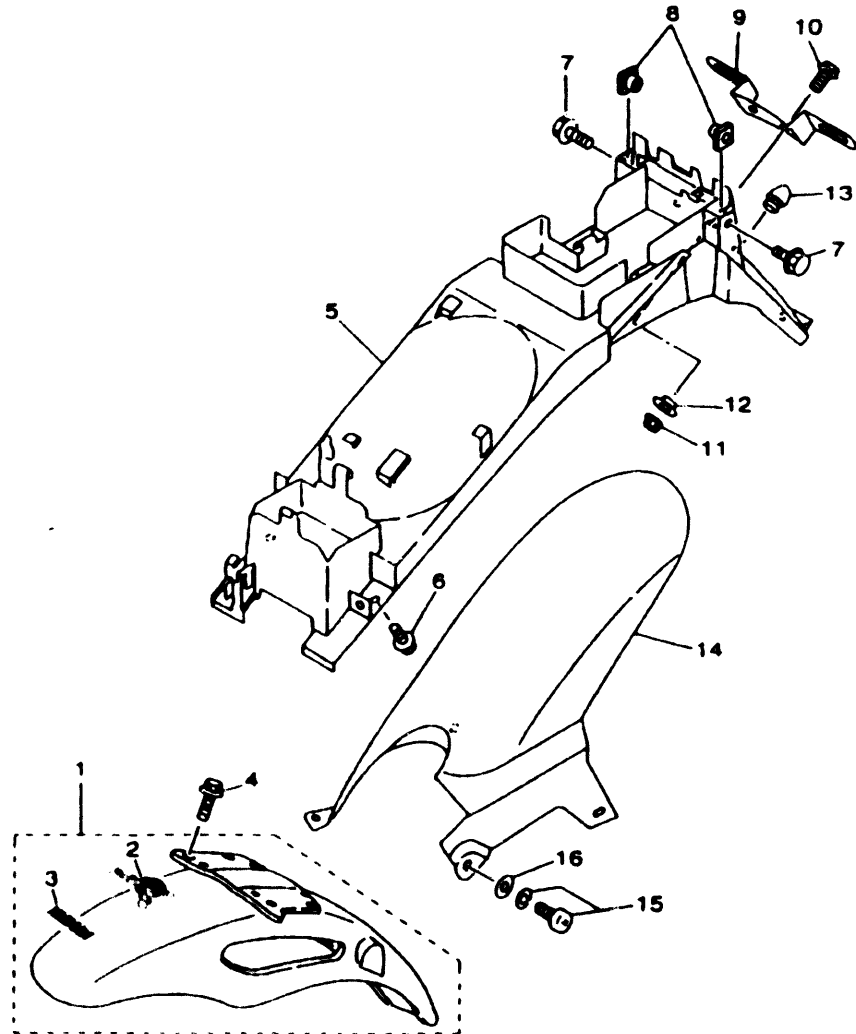

REF. N.º	CODIGO N.º	DESCRIPCION	CANT.	OBSERVACION
1	4BA-X1511-R0-TR	GUARDABARRO DELANTERO COMPLETO	1	UR ROMANTIQUE ROUGE
2	4YV-F1578-R0	• EMBLEMA	1	
3	99241-00080	• EMBLEMA, YAMAHA	1	
4	9502L-06012	PERNO, DE BRIDA	4	
5	4BA-F1611-00	GUARDABARRO TRASERO	1	
6	90119-06044	TORNILLO CON ARANDELA	2	
7	9582N-06020	TORNILLO HEXAGONAL CON VALONA	2	
8	31A-14477-00	PLACA	3	
9	4YV-F1668-00	SOPORTE DE LICENCIA	1	
10	9580M-06016	TORNILLO HEXAGONAL CON VALONA	2	
11	9570N-06500	TUERCA DE BRIDA	2	
12	90387-06500	CASQUILLO	2	
13	5T8-F1639-00	AMORTIGUADOR 2	1	
14	4BA-F1650-00	GUARDABARRO TRASERO COMPLETO	1	
15	97606-06120	TORNILLO ALOMADO CON ARANDELA	1	
16	90201-06821	ARANDELA PLANA	1	

4YV4382-0170

FIG. 18 - CUERPO CENTRAL

REF. N.º	CODIGO N.º	DESCRIPCION	CANT.	OBSERVACION
1	4BA-F1711-00-98	CUERPO CENTRAL 1	1	UR LOW GLOSS BLACK
2	4BA-F1721-00-98	TAPA CENTRAL	1	UR LOW GLOSS BLACK
3	90159-06816	TORNILLO CON ARANDELA	4	
4	90480-12014	TAPÓN PROTECTOR	2	
5	5DU-X1731-20-TR	TAPA LATERAL 3 CON CALCAS	1	UR ROMANTIQUE ROUGE
6	4YV-F1781-R0	• EMBLEMA 1	1	
7	4YV-F1782-R0	• EMBLEMA 2	1	
8	5DU-X1741-20-TR	TAPA LATERAL 4 CON CALCAS	1	UR ROMANTIQUE ROUGE
9	4YV-F1781-R0	• EMBLEMA 1	1	
10	4YV-F1782-R0	• EMBLEMA 2	1	
11	90480-12014	TAPÓN PROTECTOR	2	
12	90480-01141	TAPÓN PROTECTOR	6	
13	5DU-F1651-R0-TR	CUBIERTA DE GUARDABARRO TRAS.	1	UR ROMANTIQUE ROUGE
14	99241-00080	EMBLEMA YAMAHA	1	
15	90159-05028	TORNILLO CON ARANDELA	3	
16	2RN-F639G-00	ESPONJA	1	
17	4BA-F1751-00	DEPÓSITO DE ACEITE	1	
18	3WG-F1771-00	TAPÓN DEPÓSITO ACEITE	1	
19	9730M-06020	TORNILLO HEXAGONAL	2	
20	90480-14433	TAPÓN PROTECTOR	2	
21	90387-065G0	CASQUILLO	2	
22	4BA-F8372-00	ESPONJA	1	
23	90467-11X01	PRESILLA	1	
24	4BA-F4198-00	ASIENTO DE GOMA	1	
25	4BA-F1871-00	TANQUE DE RECUPERACIÓN	1	
26	2RN-F1815-00	TAPA	1	
27	90119-06056	TORNILLO CON ARANDELA	2	

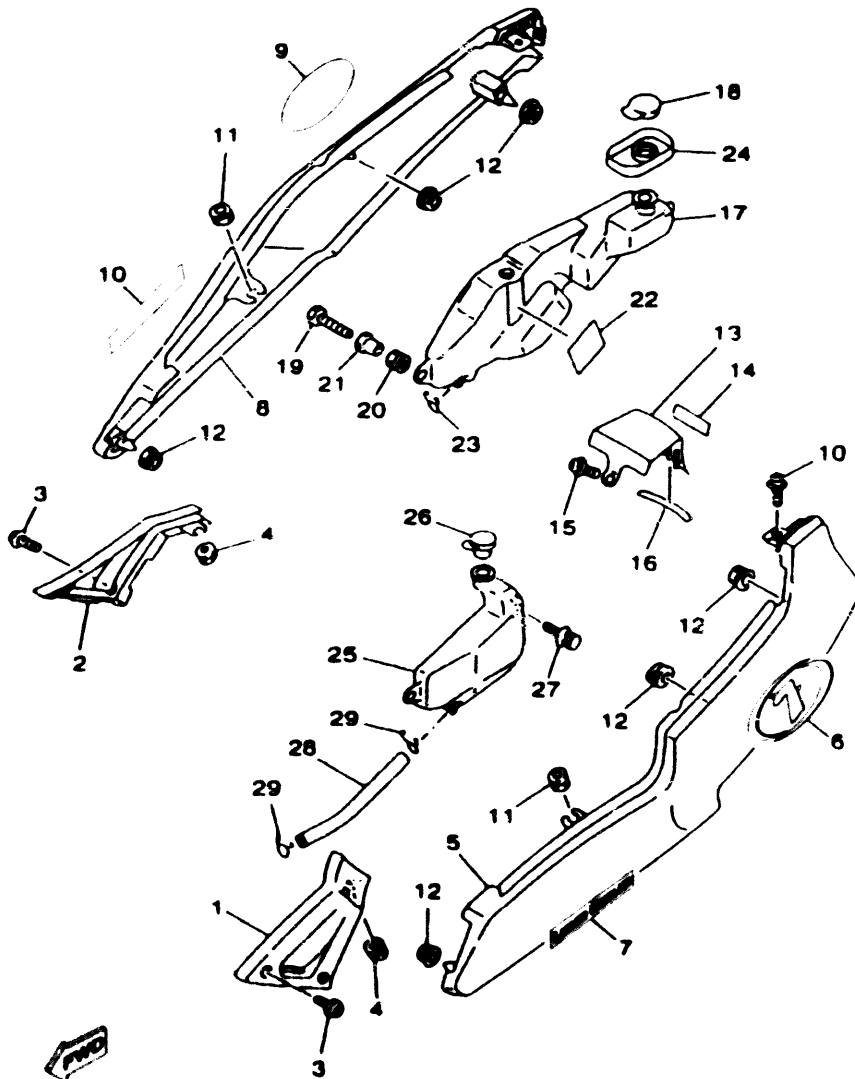

4YV4352-0180

FIG. 18 - CUERPO CENTRAL

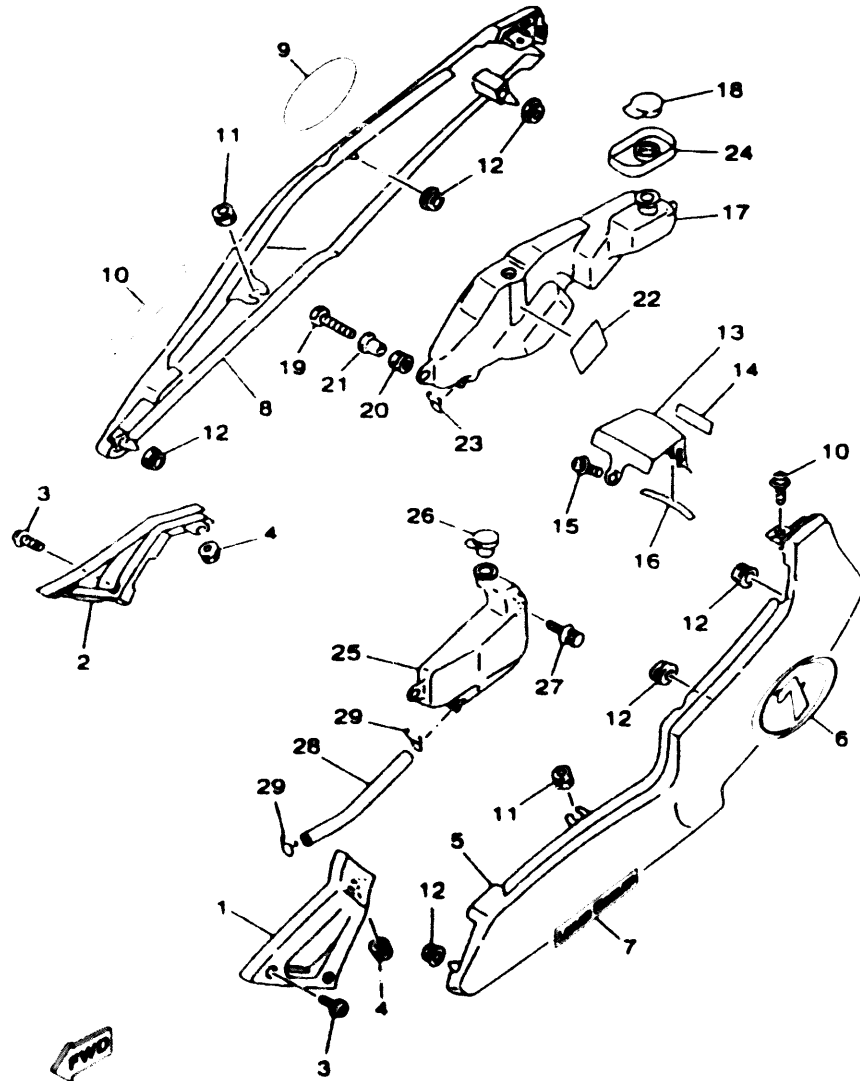

4YV4352-0100

REF. N.º	CODIGO N.º	DESCRIPCION	CANT.	OBSERVACION
28	90445-093G9	TUBO	1	
29	90467-09006	PRESILLA	2	

FIG. 19 - BRAZO TRASERO

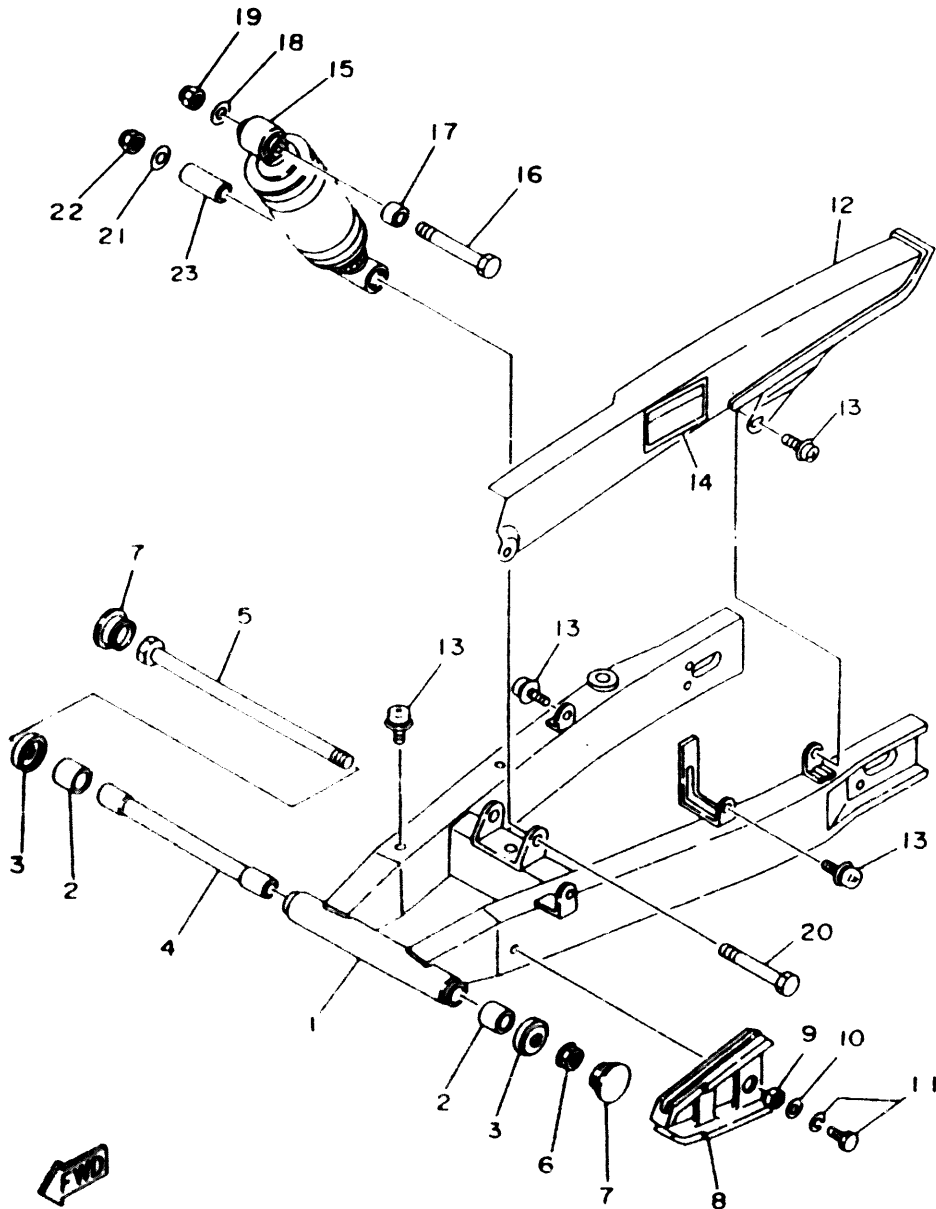

4YV2352-0190

REF. N.º	CODIGO N.º	DESCRIPCION	CANT.	OBSERVACION
1	4YV-F2110-00-98	BASCULANTE TRASERO COMP.	1	UR LOW GLOSS BLACK
2	93315-31841	COJINETE	2	
3	2RN-F2128-00	TAPA DE EMPUJE 1	2	
4	4BA-F2184-00	BUJE	1	
5	29N-22141-00	EJE DE BASCULANTE	1	
6	95607-12200	TUERCA DE AUTO-CIERRE	1	
7	4BA-F139W-00	CUBIERTA	2	
8	4YV-F2151-00	SELLO DE GUARDA	1	
9	90387-06869	CASQUILLO	1	
10	90201-06815	ARANDELA PLANA	1	
11	9750M-06416	TORNILLO HEX. CON ARANDELA	1	
12	4BA-F2311-00	CUBRECADENA	1	
13	90159-06084	TORNILLO CON ARANDELA	4	
14	4YV-F1668-20	ETIQUETA DE FRANJA	1	
15	4BA-22210-01	AMORTIGUADOR TRASERO COMPLETO	1	
16	90190-10833	TORNILLO	1	
17	90387-128E2	CASQUILLO	1	
18	90209-10229	ARANDELA	1	
19	90185-10091	TUERCA DE AUTO-CIERRE	1	
20	90101-12676	TORNILLO HEXAGONAL	1	
21	90201-124E4	ARANDELA PLANA	1	
22	95607-12100	TUERCA DE AUTO-CIERRE	1	
23	90387-124H0	CASQUILLO	1	

FIG. 20 - DIRECCION

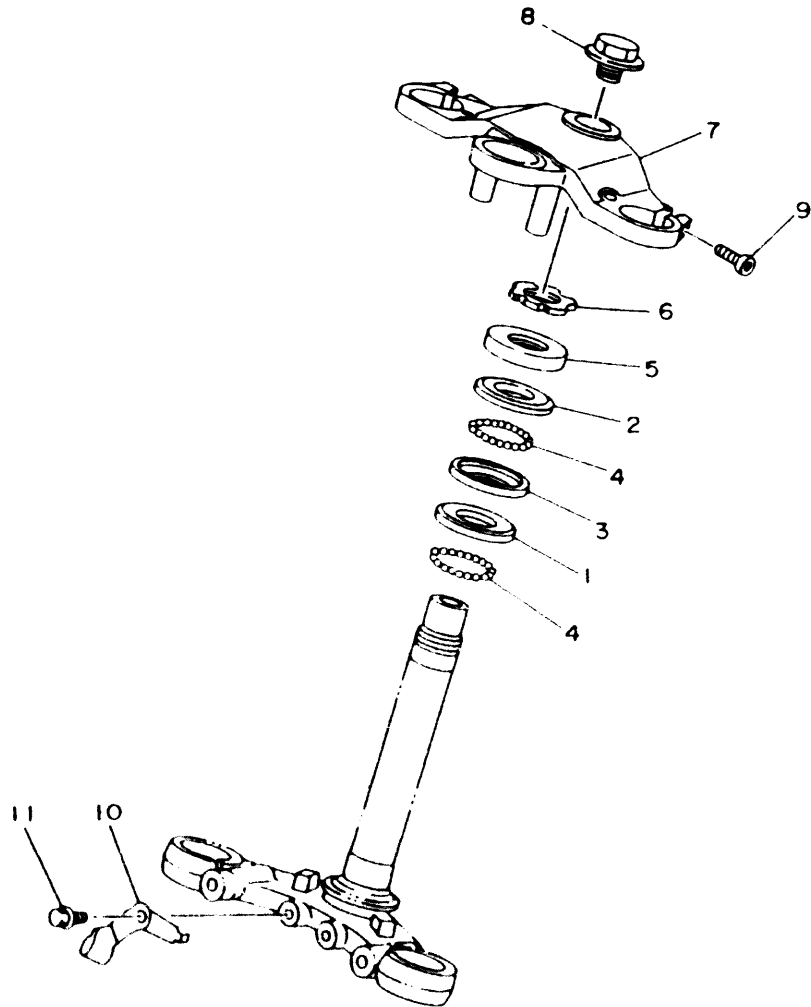

REF. N.º	CODIGO N.º	DESCRIPCION	CANT.	OBSERVACION
1	156-23412-00	PISTA DE BOLA 2	1	
2	183-23411-00	PISTA DE BOLA 1	1	
3	183-23412-00	PISTA DE BOLA 2	1	
4	93501-04011	BOLA	38	
5	21L-F3415-00	TAPA DE PISTA DE BOLA 1	1	
6	90179-25X00	TUERCA	1	
7	4BA-F3435-00-98	PLATINA SUPERIOR DE MANILLAR	1	UR LOW GLOSS BLACK
8	90105-14060	TORNILLO CON VALONA	1	
9	9131L-08035	TORNILLO ALLEN	2	
10	4BA-F3466-00	GRAMPA	1	
11	9580M-06012	TORNILLO HEXAGONAL CON VALONA	1	



4YV2352-0200

FIG. 21 - HORQUILLA DELANTERA

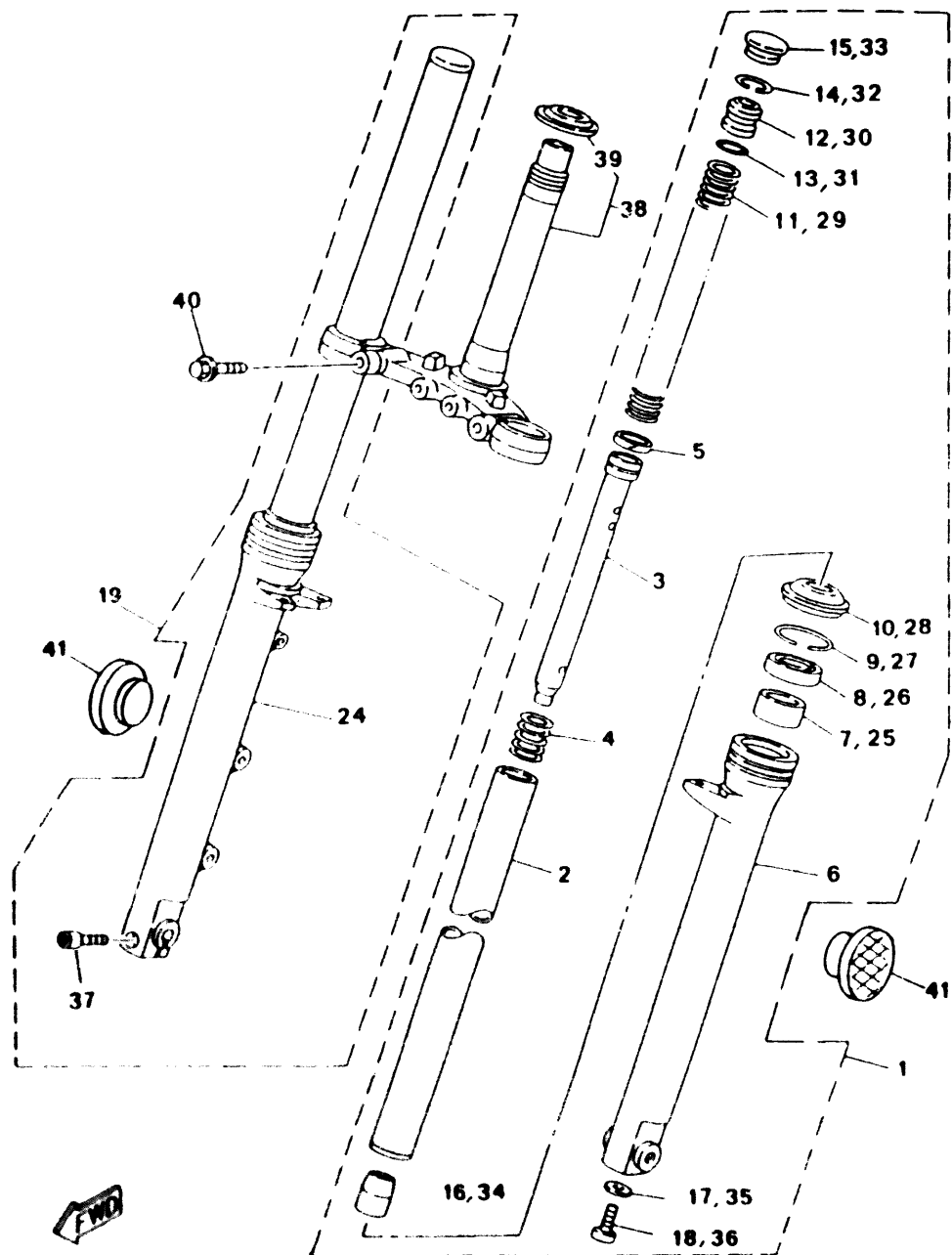

4YV2352-0210

REF. N.º	CODIGO N.º	DESCRIPCION	CANT.	OBSERVACION
1	4BA-F3102-00-98	BRAZO HORQUILLA DEL. COMP. (I)	1	UR LOW GLOSS BLACK
2	2RN-F3110-00	TUBO INTERIOR COMPLETO 1	1	
3	4BA-23171-01	PISTON HORQUILLA DELANT.	1	
4	2RN-F3151-00	RESORTE DE REBOTE	1	
5	2RN-F3157-00	ANILLO DE PISTON	1	
6	4BA-F3126-00-98	TUBO EXTERIOR 1	1	UR LOW GLOSS BLACK
7	1GU-23125-00	METAL CORREDIZO 1	1	
8	93110-33023	RETEN ACEITE	1	
9	2RN-F3156-00	PRESILLA RETEN DE ACEITE	1	
10	1GU-23144-00	GUARDAPOLVO	1	
11	4BA-F3141-00	RESORTE HOQUILLA DELANT. 1		
12	2RN-F3111-00	TAPON	1	
13	93210-23858	ANILLO O	1	
14	93450-31114	PRESILLA REDONDA	1	
15	2RN-F3154-00	TAPON TUBO INTERIOR	1	
16	4BA-F3173-00	VASTAGO AHUSADO	1	
17	90201-081E6	ARANDELA PLANA	1	
18	90110-08X00	TORNILLO ALLEN	1	
19	4BA-F3103-00-98	BRAZO HORQUILLA DEL. COMP. (D)	1	UR LOW GLOSS BLACK
20	2RN-F3110-00	TUBO INTERIOR COMPLETO 1	1	
21	4BA-23171-01	PISTON HORQUILLA DELANT.	1	
22	2RN-F3151-00	RESORTE DE REBOTE	1	
23	2RN-F3157-00	ANILLO DE PISTON	1	
24	4BA-F3136-00-98	TUBO EXTERIOR 2	1	UR LOW GLOSS BLACK
25	1GU-23125-00	METAL CORREDIZO 1	1	
26	93110-33023	RETEN ACEITE	1	
27	2RN-F3156-00	PRESILLA RETEN DE ACEITE	1	

FIG. 21 - HOQUILLA DELANTERA

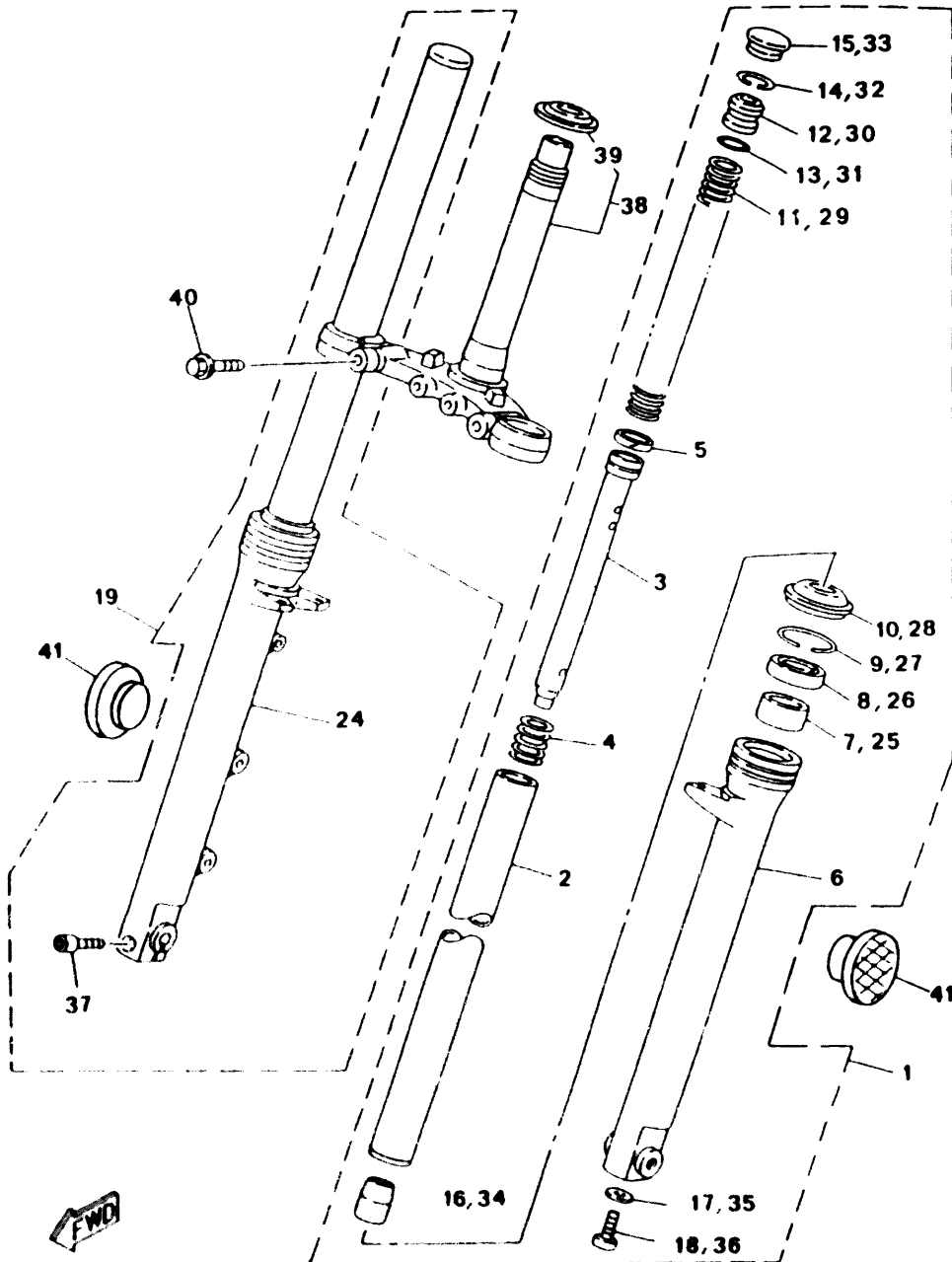

REF. N.º	CODIGO N.º	DESCRIPCION	CANT.	OBSERVACION
28	1GU-23144-00	GUARDAPOLVO	1	
29	4BA-F3141-00	RESORTE HORQUILLA DELANT.	1	
30	2RN-F3111-00	TAPON	1	
31	93210-23858	ANILLO O	1	
32	93450-31114	PRESILLA REDONDA	1	
33	2RN-F3154-00	TAPON TUBO INTERIOR	1	
34	4BA-F3173-00	VASTAGO AHUSADO	1	
35	90201-081E6	ARANDELA PLANA	1	
36	90110-08X00	TORNILLO ALLEN	1	
37	9131L-08030	TORNILLO ALLEN	1	
38	2RN-F3340-00-33	SOPORTE INFERIOR COMPLETO	1	UR YAMAHA BLACK
39	156-23411-00	PISTA DE BOLA 1	1	
40	9582M-10030	TORNILLO HEXAGONAL CON VALONA	2	
41	4YV-H5111-00	REFLECTOR	2	

4YV2352-0210

FIG. 22 - DEPOSITO DE COMBUSTIBLE

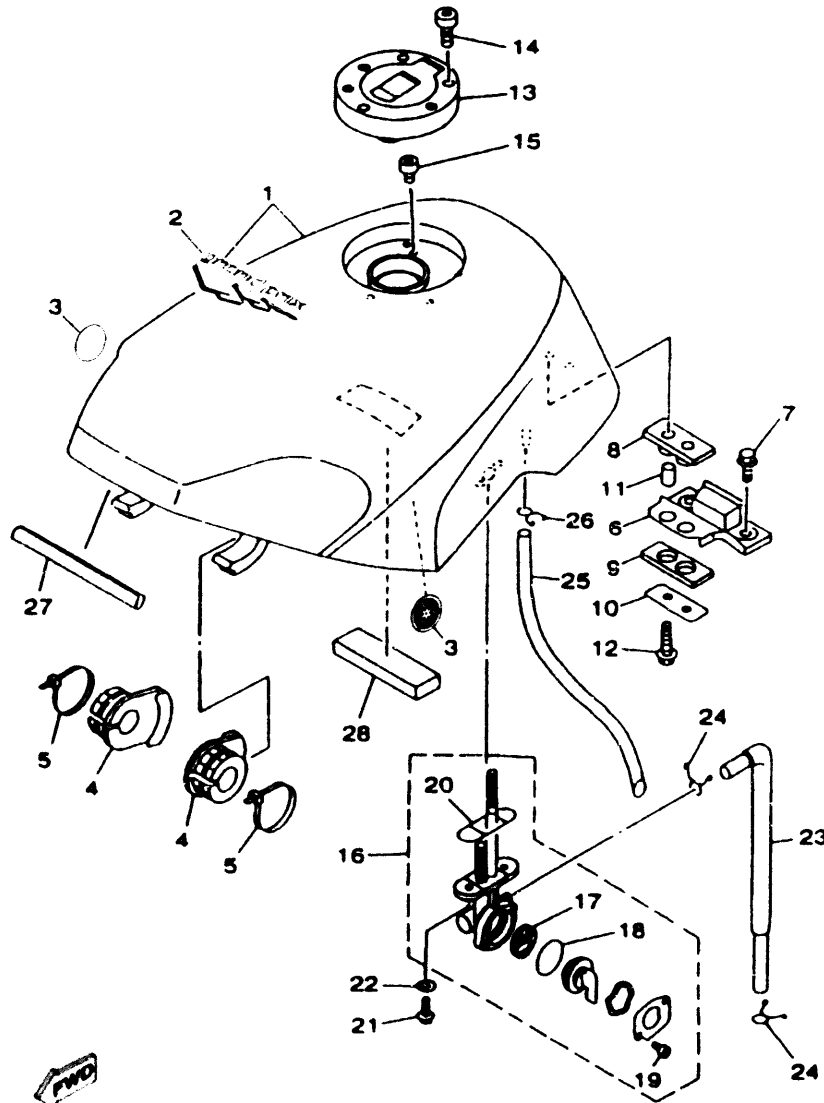

FWD
4YV4352-0220

REF. N.º	CODIGO N.º	DESCRIPCION	CANT.	OBSERVACION
1	4BA-X4110-00-3X	DEPÓSITO DE COMBUSTIBLE COMP.	1	UR ROMANTIQUE ROUGE
2	4YV-F4231-R0	• EMBLEMA	1	
3	3TH-F4256-00	• EMBLEMA	2	DIAPASON
4	4BA-F4182-00	GOMA AMORTIGUADOR DE MONTAJE 2	2	
5	90464-13804	BRIDA	2	
6	4BA-F4192-00	SOPORTE DE DEPÓSITO COMBUST. 2	1	
7	9580N-06016	TORNILLO HEXAGONAL CON VALONA	2	
8	4BA-F4181-00	GOMA AMORTIGUADOR DE MONTAJE 1	1	
9	4BA-F4183-00	GOMA AMORTIGUADOR DE MONTAJE 3	1	
10	4BA-F4186-00	ARANDELA ESPECIAL	1	
11	90387-06553	CASQUILLO	2	
12	9580N-06025	TORNILLO HEXAGONAL CON VALONA	2	
13	4FU-24610-00	TAPÓN COMPLETO A	1	
14	90110-05806	TORNILLO CABEZA HEXAGONAL	3	
15	9131L-05010	TORNILLO ALLEN	1	
16	23F-24500-01	GRIFO DE COMBUSTIBLE 1	1	
17	3AJ-24523-00	• VÁLVULA	1	
18	3AJ-24534-00	• SELLO DE GRIFO	1	
19	98503-03008	• TORNILLO ALOMADO CON (+)	2	
20	4X8-24512-00	• JUNTA	1	
21	90149-06011	TORNILLO	2	
22	90202-05193	ARANDELA DE PLACA	2	
23	4BA-F4313-00	TUBO 3	1	
24	90467-09006	PRESILLA	2	
25	90445-10366	TUBO	1	
26	90467-09006	PRESILLA	1	
27	2RN-F4188-00	MOLDURA DEPÓSITO COMBUST.	1	

FIG. 22 - DEPOSITO DE COMBUSTIBLE

REF. N.º	CODIGO N.º	DESCRIPCION	CANT.	OBSERVACION
28	2RN-F414G-00	SELLO	1	

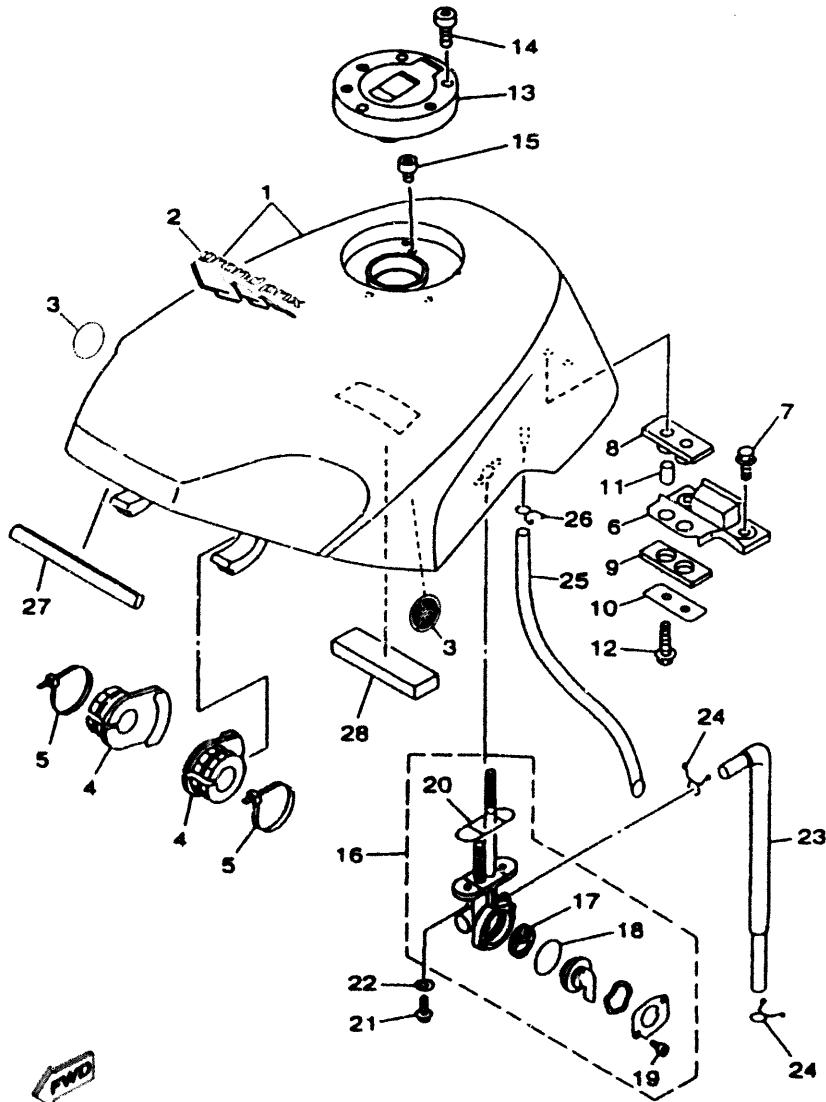

FWD
4YV4352-0220

FIG. 23 - ASIENTO

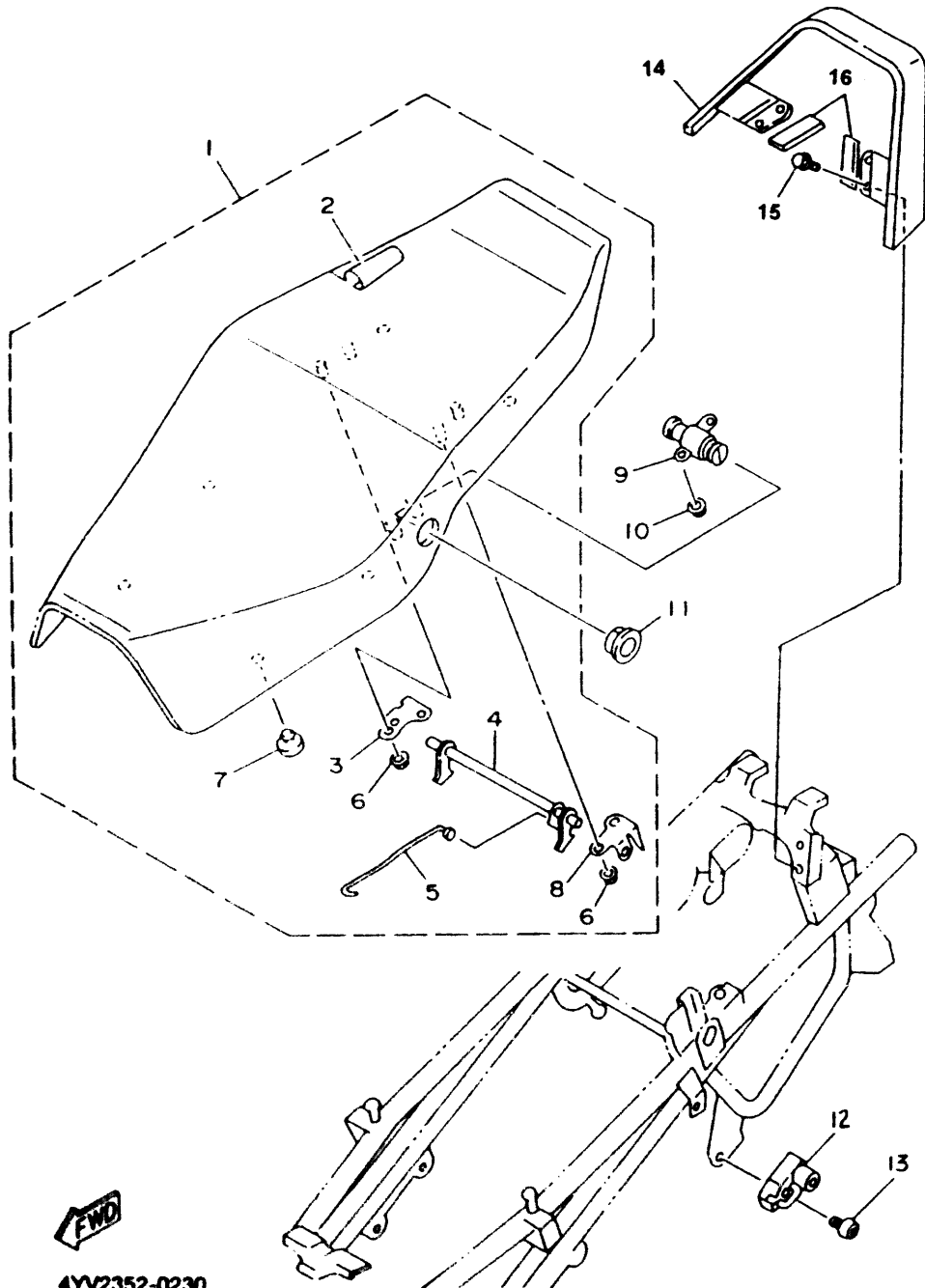

REF. N.º	CODIGO N.º	DESCRIPCION	CANT.	OBSERVACION
1	4BA-F4730-10	ASIENTO DOBLE COMPLETO	1	UR YAMAHA BLACK
2	4BA-F4731-10	• FUNDA DE SILLIN DOBLE	1	UR YAMAHA BLACK
3	4BA-F4718-00	• SOPORTE DE ASIENTO	1	
4	4BA-F4776-00	• PALANCA DE ASIENTO	1	
5	4BA-F478F-00	• VARILLA, CONECTORA	1	
6	90179-06403	• TUERCA	4	
7	2RN-F4741-00	• COJIN DE ASIENTO	1	
8	4BA-F4728-00	• SOPORTE DE ASIENTO	1	
9	47X-24708-00	CIERRE SILLIN COMPLETO	1	
10	9570N-05500	TUERCA DE BRIDA	2	
11	2RN-F4796-00	CUBIERTA	1	
12	4R8-21308-00	ENGANCHE COMPLETO DE CASCO	1	
13	90149-06150	TORNILLO	1	
14	4BA-F4773-10-98	ASIDERO DE ASIENTO	1	UR LOW GLOSS BLACK
15	95821-06010	TORNILLO	4	
16	4BA-F4785-00	MOLDURA DE ASIDERO	2	



4YV2352-0230

FIG. 24 - RUEDA DELANTERA

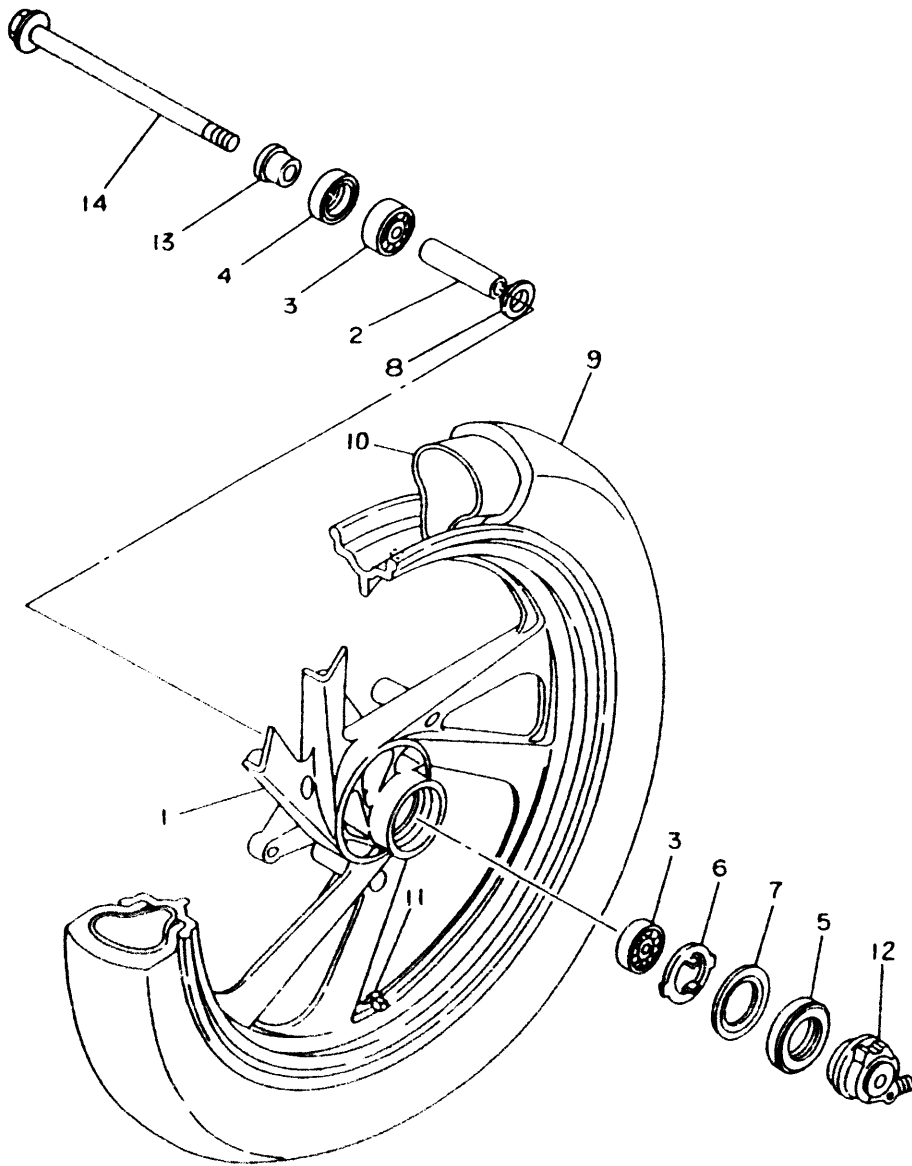

REF. N.º	CODIGO N.º	DESCRIPCION	CANT.	OBSERVACION
1	4BA-F5168-00-33	LLANTA FUNDIDA DELANTERA	1	UR YAMAHA BLACK
2	90560-12332	SEPARADOR	1	
3	93306-30101	COJINETE (B6301)	2	
4	93106-20805	RETEN ACEITE	1	
5	93105-45804	RETEN ACEITE	1	
6	2RN-F5149-U0	PLACA CONEXION REENVIO	1	
7	2RN-F5846-00	RETEN DE EMBRAGUE	1	
8	3PE-F5315-A0	SEPARADOR CON VALONA	1	
9		NEUMATICO 90/80-17	1	UR PIRELLI
		NEUMATICO 90/80-17	1	UR CHENG-SHIN
10		CAMARA	1	UR PIRELLI
		CAMARA	1	UR CHENG-SHIN
11		CONTRAPESO	1	LM
		CONTRAPESO	1	LM
		CONTRAPESO	1	LM
12	2L4-25190-20	UNIDAD DE REENVIO CUENTA KMS.	1	
13	90387-123N2	CASQUILLO	1	
14	51Y-25181-00	EJE DE RUEDA	1	



4YV2352-0240

CONTENIDO

MOTOR

Fig. 1 CILINDRO Y CULATA.....	B2
Fig. 2 GIGÜEÑAL. PISTÓN.....	B3
Fig. 3 BOMBA DE AGUA.....	B4
Fig. 4 RADIADOR.....	B5
Fig. 5 BOMBA DE ACEITE.....	B6
Fig. 6 ADMISIÓN.....	B7
Fig. 7 CARBURADOR.....	B8-B9
Fig. 8 TUBO DE ESCAPE.....	B10
Fig. 9 CÁRTER.....	B11
Fig. 10 CUBIERTA DE CÁRTER 1.....	B12
Fig. 11 EMBRAGUE.....	B13
Fig. 12 TRANSMISIÓN.....	B14
Fig. 13 ENGR. DE TACÓMETRO.....	B15
Fig. 14 LEVA DE CAMBIO. HORQ.....	C2
Fig. 15 EJE DE CAMBIO. PEDAL.....	C3

CHASSIS

Fig. 16 BASTIDOR.....	C4
Fig. 17 GUARDABARROS.....	C5
Fig. 18 CUBIERTA LATERAL.....	C6-C7
Fig. 19 BRAZO TRASERO.....	C8
Fig. 20 DIRECCIÓN.....	C9
Fig. 21 HORQUILLA DELANTERA.....	C10-C-11
Fig. 22 DEPÓSITO DE COMBUSTIBLE.....	C12-C-13
Fig. 23 ASIENTO.....	C14
Fig. 24 RUEDA DELANTERA.....	C15

Fig. 25 PINZA FRENO DELANTERO.....	D2
Fig. 26 RUEDA TRASERA.....	D3-D4
Fig. 27 PINZA FRENO TRASERO.....	D5
Fig. 28 MANILLAR Y CABLES.....	D6
Fig. 29 BOMBA DE FRENO DELANTERO.....	D7
Fig. 30 ESTRIBERAS Y CABALLETE.....	D8-D9
Fig. 31 CILINDRO MAESTRO TRASERO.....	D10
Fig. 32 CÚPULA CARENADO.....	D11
Fig. 33 CARENADO.....	D12-D13
Fig. 34 GENERADOR.....	D14
Fig. 35 INTERMITENTES.....	D15
Fig. 36 PANEL DE C.KMS. Y TESTIGOS.....	E2
Fig. 37 FARO DELANTERO.....	E3
Fig. 38 PILOTO TRASERO.....	E4
Fig. 39 CONMUTADORES Y MANETAS.....	E5
Fig. 40 GRUPO ELÉCTRICO 1.....	E6-E7

ÍNDICE

ÍNDICE NUMÉRICO.....	M1 ~ M3
----------------------	---------

CONTENIDO

MOTOR

Fig. 1 CILINDRO Y CULATA.....	B2
Fig. 2 GIGÜEÑAL. PISTÓN.....	B3
Fig. 3 BOMBA DE AGUA.....	B4
Fig. 4 RADIADOR.....	B5
Fig. 5 BOMBA DE ACEITE.....	B6
Fig. 6 ADMISIÓN.....	B7
Fig. 7 CARBURADOR.....	B8-B9
Fig. 8 TUBO DE ESCAPE.....	B10
Fig. 9 CÁRTER.....	B11
Fig. 10 CUBIERTA DE CÁRTER 1.....	B12
Fig. 11 EMBRAGUE.....	B13
Fig. 12 TRANSMISIÓN.....	B14
Fig. 13 ENGR. DE TACÓMETRO.....	B15
Fig. 14 LEVA DE CAMBIO. HORQ.....	C2
Fig. 15 EJE DE CAMBIO. PEDAL.....	C3

CHASSIS

Fig. 16 BASTIDOR.....	C4
Fig. 17 GUARDABARROS.....	C5
Fig. 18 CUBIERTA LATERAL.....	C6-C7
Fig. 19 BRAZO TRASERO.....	C8
Fig. 20 DIRECCIÓN.....	C9
Fig. 21 HORQUILLA DELANTERA.....	C10-C-11
Fig. 22 DEPÓSITO DE COMBUSTIBLE.....	C12-C-13
Fig. 23 ASIENTO.....	C14
Fig. 24 RUEDA DELANTERA.....	C15

Fig. 25 PINZA FRENO DELANTERO.....	D2
Fig. 26 RUEDA TRASERA.....	D3-D4
Fig. 27 PINZA FRENO TRASERO.....	D5
Fig. 28 MANILLAR Y CABLES.....	D6
Fig. 29 BOMBA DE FRENO DELANTERO.....	D7
Fig. 30 ESTRIBERAS Y CABALLETE.....	D8-D9
Fig. 31 CILINDRO MAESTRO TRASERO.....	D10
Fig. 32 CÚPULA CARENADO.....	D11
Fig. 33 CARENADO.....	D12-D13
Fig. 34 GENERADOR.....	D14
Fig. 35 INTERMITENTES.....	D15
Fig. 36 PANEL DE C.KMS. Y TESTIGOS.....	E2
Fig. 37 FARO DELANTERO.....	E3
Fig. 38 PILOTO TRASERO.....	E4
Fig. 39 CONMUTADORES Y MANETAS.....	E5
Fig. 40 GRUPO ELÉCTRICO 1.....	E6-E7

ÍNDICE

ÍNDICE NUMÉRICO.....	M1 ~ M3
----------------------	---------

FIG. 25 - FRENO DELANTERO

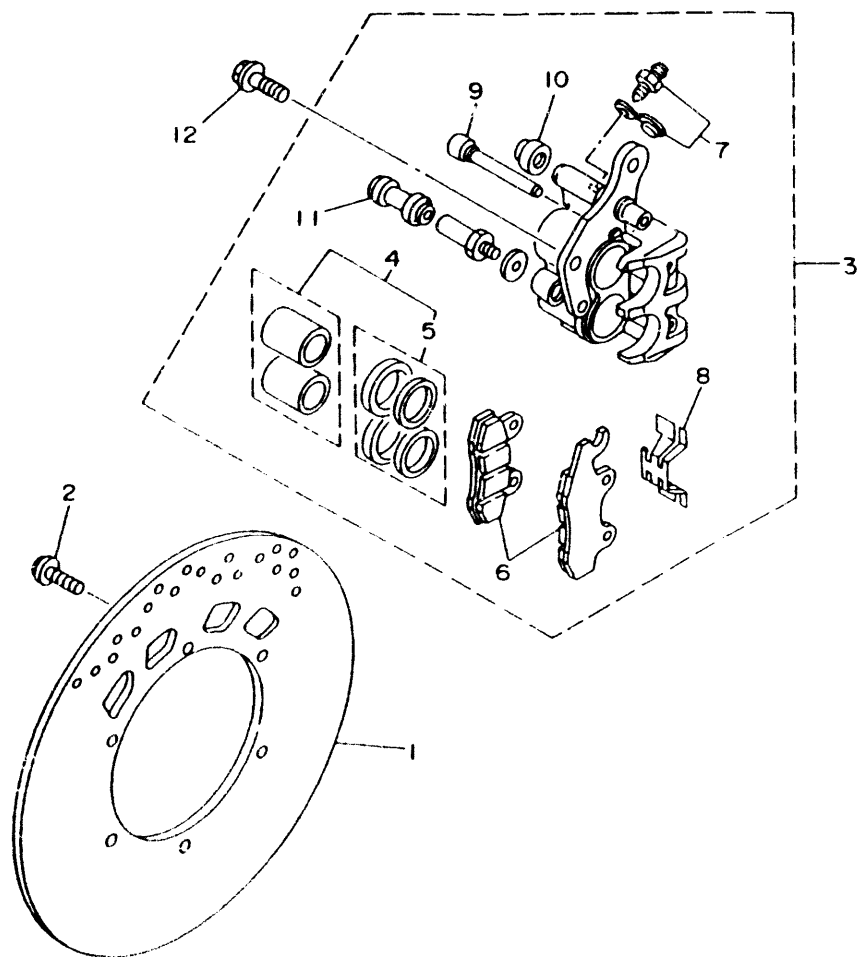

REF. N.º	CODIGO N.º	DESCRIPCION	CANT.	OBSERVACION
1	4BA-2582U-00	DISCO DE FRENO (DERECHO)	1	
2	90149-08814	TORNILLO	6	
3	4BA-2580U-01	CALIBRE COMPLETO (DERECHO)	1	
4	3LD-W0057-00	• PISTON COMPLETO CALIBRE	1	
5	3JD-W0047-00	•• JUEGO DE SELLO DE CALIBRE	1	
6	3LD-W0045-10	• JUEGO DE COJIN DE FRENO	1	
7	1UY-W0048-50	• JUEGO DE TORNILLO RESPIRADERO	1	
8	3LD-25934-01	• RESORTE, COJIN	1	
9	3LD-25924-00	• PASADOR	2	
10	3JD-25917-00	• FUNDA DE CALIBRE	1	
11	1UY-25937-51	• FUNDA	1	
12	90105-10634	TORNILLO CON VALONA	2	



4YV2352-0250

FIG. 26 - RUEDA TRASERA

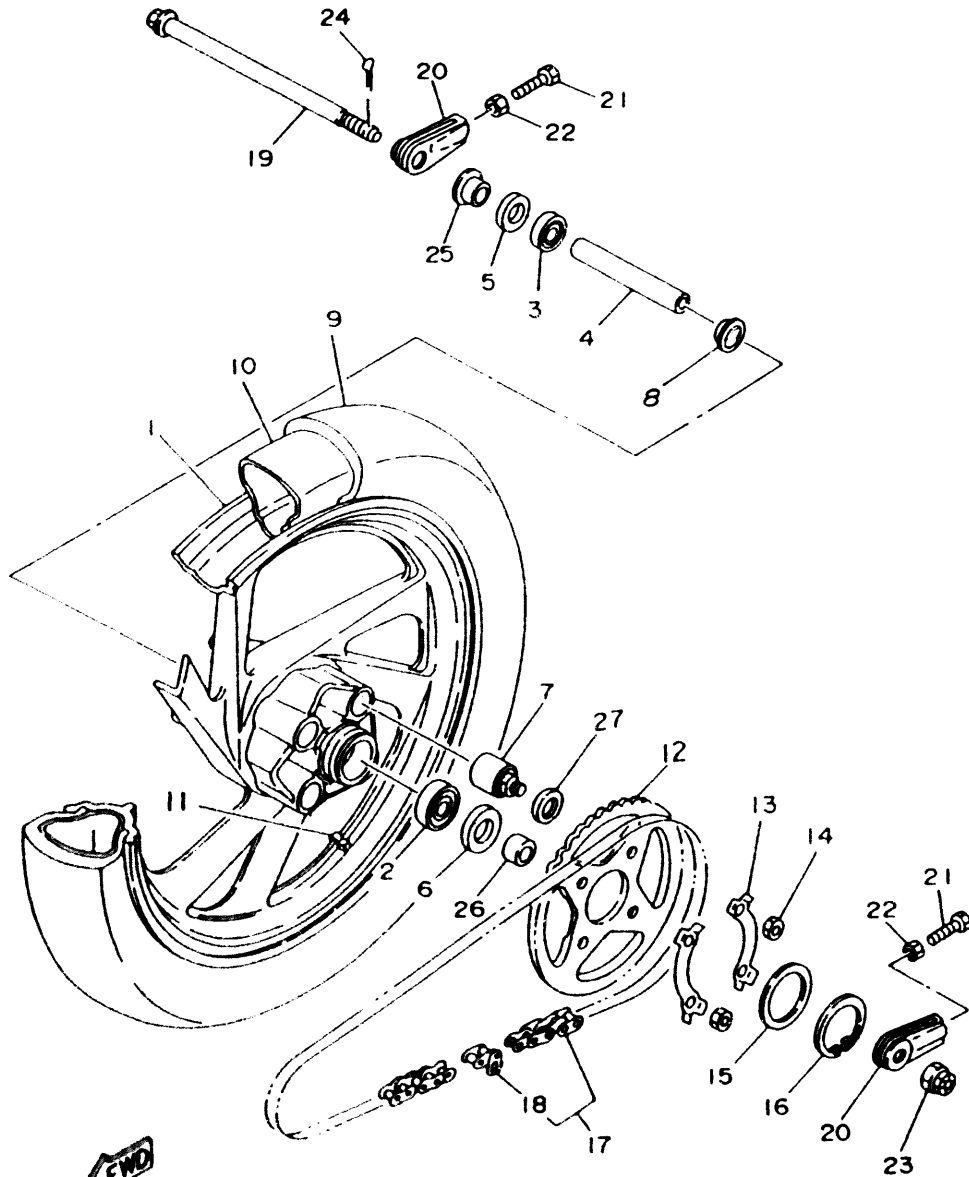

4YV2352-0260

REF. N.º	CODIGO N.º	DESCRIPCION	CANT.	OBSERVACION
1	4BA-F5338-00-33	LLANTA FUNDICION TRASERA	1	UR YAMAH BLACK
2	93306-30202	COJINETE	1	
3	93306-20226	COJINETE	1	
4	93560-15823	SEPARADOR	1	
5	93102-22858	RETEN ACEITE	1	
6	93102-22826	RETEN ACEITE	1	
7	4L1-25364-00	GOMA AMORTIGUADORA	4	
8	4BA-F5315-00	SEPARADOR CON VALONA	1	
9		NEUMATICO 100/80-17	1	UR PIRELLI
		NEUMATICO 100/80-17	1	UR CHENG-SHIN
10		CAMARA	1	UR PIRELLI
		CAMARA	1	UR CHENG-SHIN
11		CONTRAPESO	1	LM
12	4YV-F5446-10	CORONA	1	
13	2RN-F5412-00	ARANDELA	2	
14	90170-10X03	TUERCA	4	
15	90201-54X00	ARANDELA PLANA	1	
16	93410-52821	PRESILLA REDONDA TIPO S	1	
17	94581-91132	CADENA	1	
18	94681-91001	CONECTOR DE CADENA	1	
19	4BA-25381-00	EJE DE RUEDA	1	
20	2RN-F5389-00	TENSOR DE CADENA 2	2	
21	90101-08846	TORNILLO HEXAGONAL	2	
22	9530L-08600	TUERCA HEXAGONAL	2	
23	90171-14809	TUERCVA ENTALLADA	1	
24	91404-30028	PASADOR DE CHAVETA	1	
25	90387-153N7	CASQUILLO	1	

FIG. 26 - RUEDA TRASERA

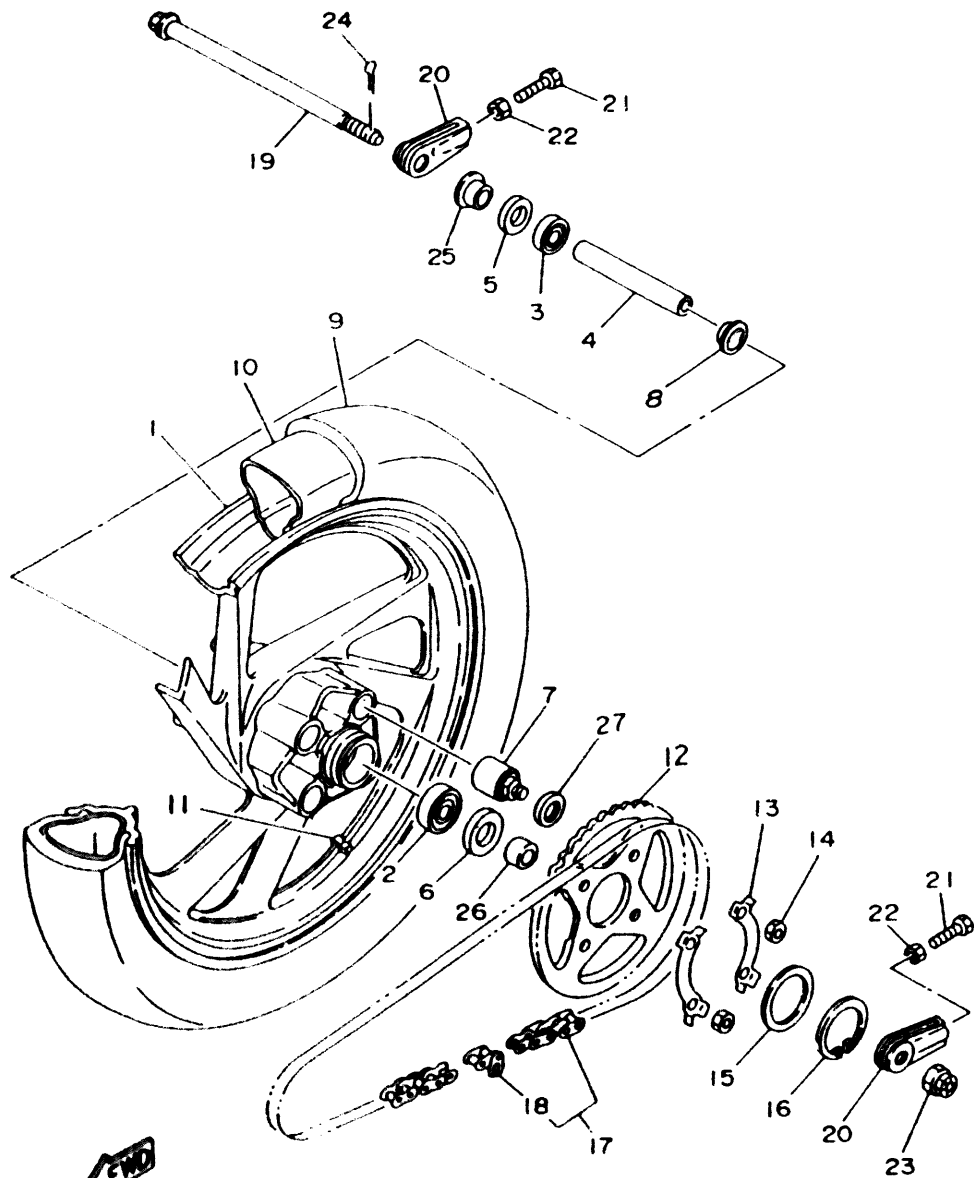

REF. N.º	CODIGO N.º	DESCRIPCION	CANT.	OBSERVACION
26	90387-15765	CASQUILLO	1	
27	90560-23219	SEPARADOR	4	



4YV2352-0260

FIG. 27 - PINZA FRENO TRASERO

REF. N.º	CODIGO N.º	DESCRIPCION	CANT.	OBSERVACION
----------	------------	-------------	-------	-------------

1	4BA-2582W-00	DISCO DE FRENO TRASERO 2	1	
2	90149-08814	TORNILLO	4	
3	4BA-2580W-00	CALIBRE COMPLETO TRASERO 2	1	
4	2KF-W0057-00	• PISTON COMPLETO CALIBRE 1	1	
5	34X-W0047-00	•• JUEGO DE SELLO DE CALIBRE	2	
6	5R2-25937-00	• FUNDA	1	
7	34X-25937-00	• FUNDA	1	
8	51L-W0048-00	• JUEGO DE TORNILLO RESPIRADERO	1	
9	3FY-W0045-00	• JUEGO DE COJIN DE FRENO	1	
10	2KF-25919-10	• SOPORTE DE COJIN	2	
11	2GV-25926-00	• PERNO	1	
12	34X-25845-00	• TAPA DE INDICADOR	1	
13	3FY-25827-00	• CUNA DE CALIBRE	1	
14	90201-106F2	ARANDELA PLANA	1	
15	9582L-10030	TORNILLO HEXAGONAL CON VALONA	1	

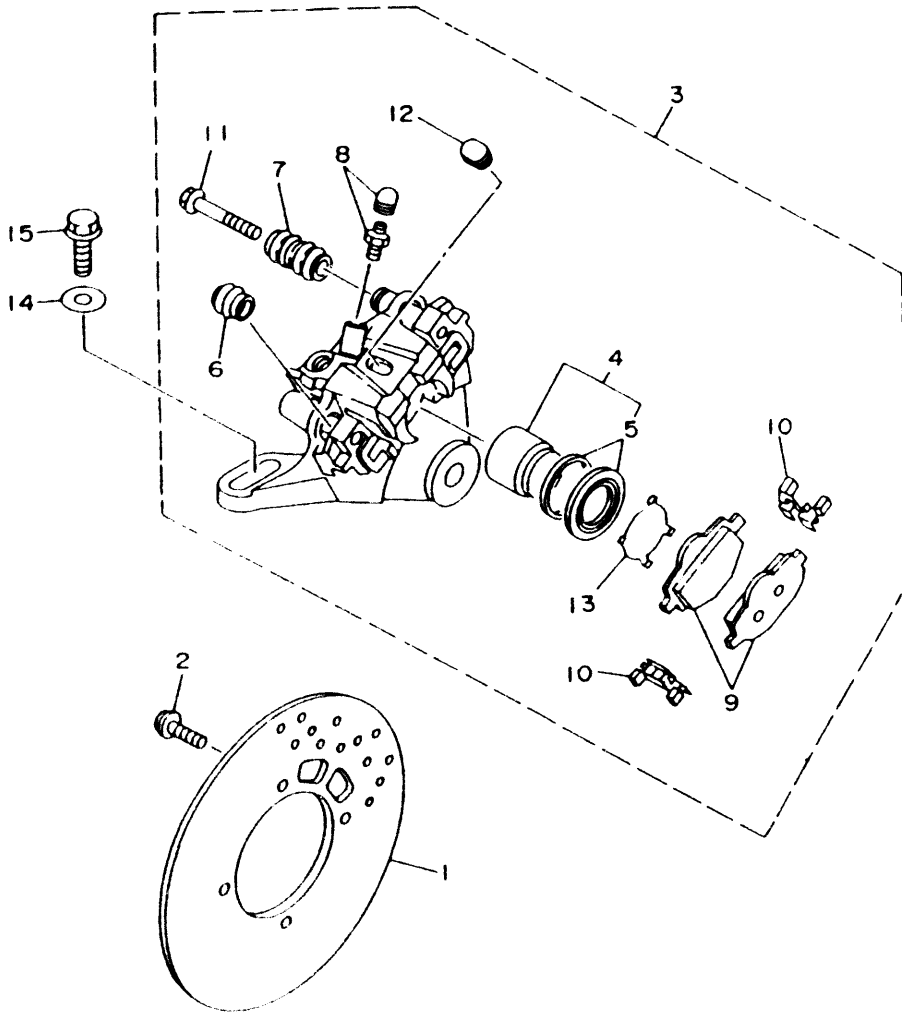

4YV2352-0270

FIG. 26 - MANILLAR Y CABLES

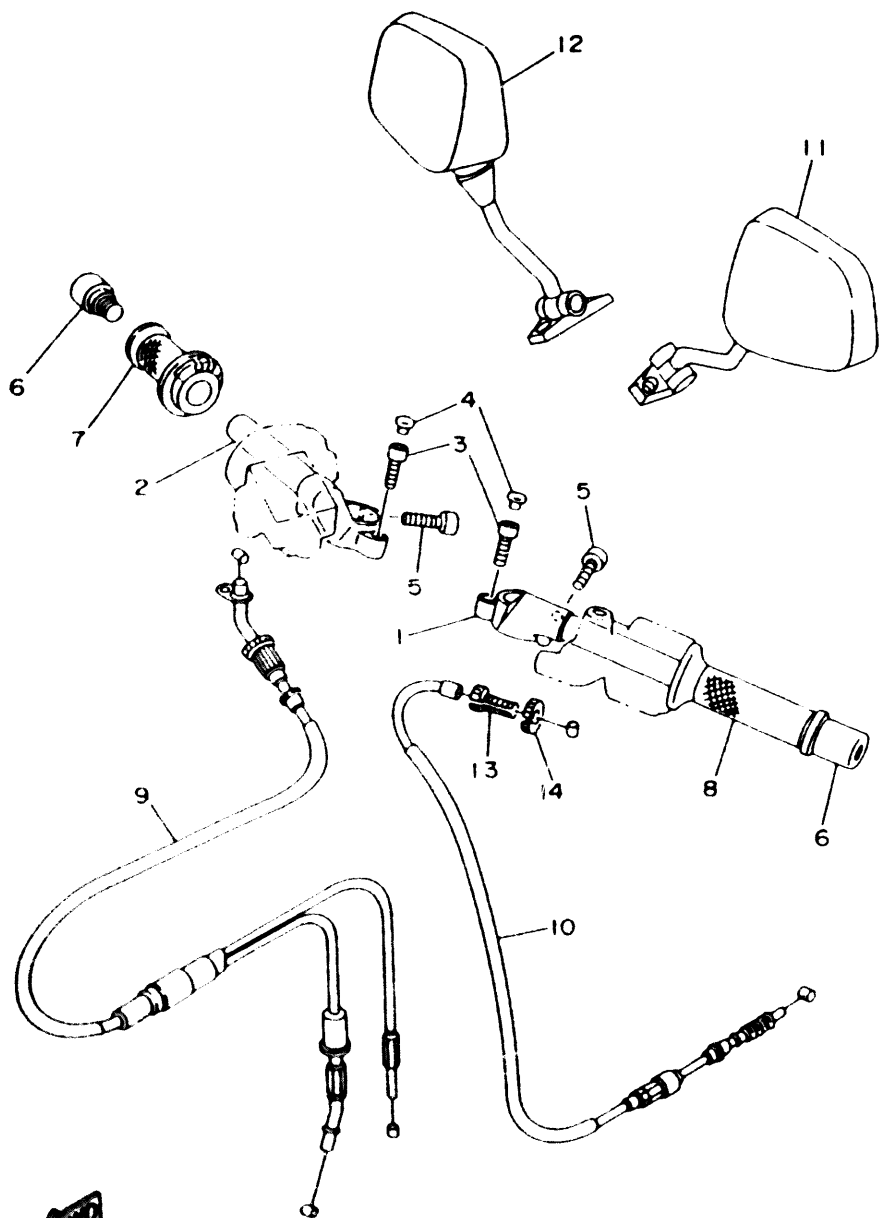

REF. N.º	CODIGO N.º	DESCRIPCION	CANT.	OBSERVACION
1	4BA-F6121-20	MANILLAR (MI)	1	
2	4BA-F6122-20	MANILLAR (MD)	1	
3	9131L-06020	TORNILLO ALLEN	2	
4	2RN-F3469-00	TAPA CABEZA DE TORNILLO	2	
5	90110-08X00	TORNILLO ALLEN	2	
6	2RN-F6246-00	EXTREMO DE EMPUÑADURA	2	
7	4BA-F6240-00	EMPUÑADURA COMPLETA	1	
8	2RN-F6241-00	EMPUÑADURA (MI)	1	
9	4YV-F6260-10	CABLE GAS Y BOMBA	1	
10	4YV-F6335-00	CABLE DE EMBRAGUE	1	
11	4BA-F6280-00	ESPEJO COMPLETO (MI)	1	
12	4BA-F6290-00	ESPEJO COMPLETO (MD)	1	
13	90123-08046	TORNILLO	1	
14	90179-08148	TUERCA	1	

4YV2352-0280

FIG. 29 - BOMBA DE FRENO DELANTERO

REF. N.º	CODIGO N.º	DESCRIPCION	CANT.	OBSERVACION
1	2RJ-25870-00	CILINDRO MAESTRO COMPLETO	1	
2	23L-W0041-00	• JUEGO DE CILINDRO MAESTRO	1	
3	4L0-25854-00	• DIAFRAGMA TANQUE RESERVA	1	
4	4H7-25852-00	• TAPA DE TANQUE DE RESERVA	1	
5	98706-04012	• TORNILLO AVELLANADO CON (X)	1	
6	4L0-25867-00	SOPORTE DE CILINDRO MAESTRO	1	
7	97026-06025	TORNILLO HEXAGONAL	2	
8	92906-06600	ARANDELA PLANA	2	
9	5T8-H3936-10	BANDA	1	
10	4BA-25872-01	MANGUERA DE FRENO 1	1	
11	4BA-F5876-00	SOPORTE DE MANGUERA FRENO 2	1	
12	9502M-06025	PERNO. DE BRIDA	1	
13	2RN-F5862-00	FUNDA DE CILINDRO MAESTRO	1	
14	90401-10159	PERNO DE UNION	2	
15	90201-10118	ARANDELA PLANA	4	
16	90338-09800	TAPON	2	

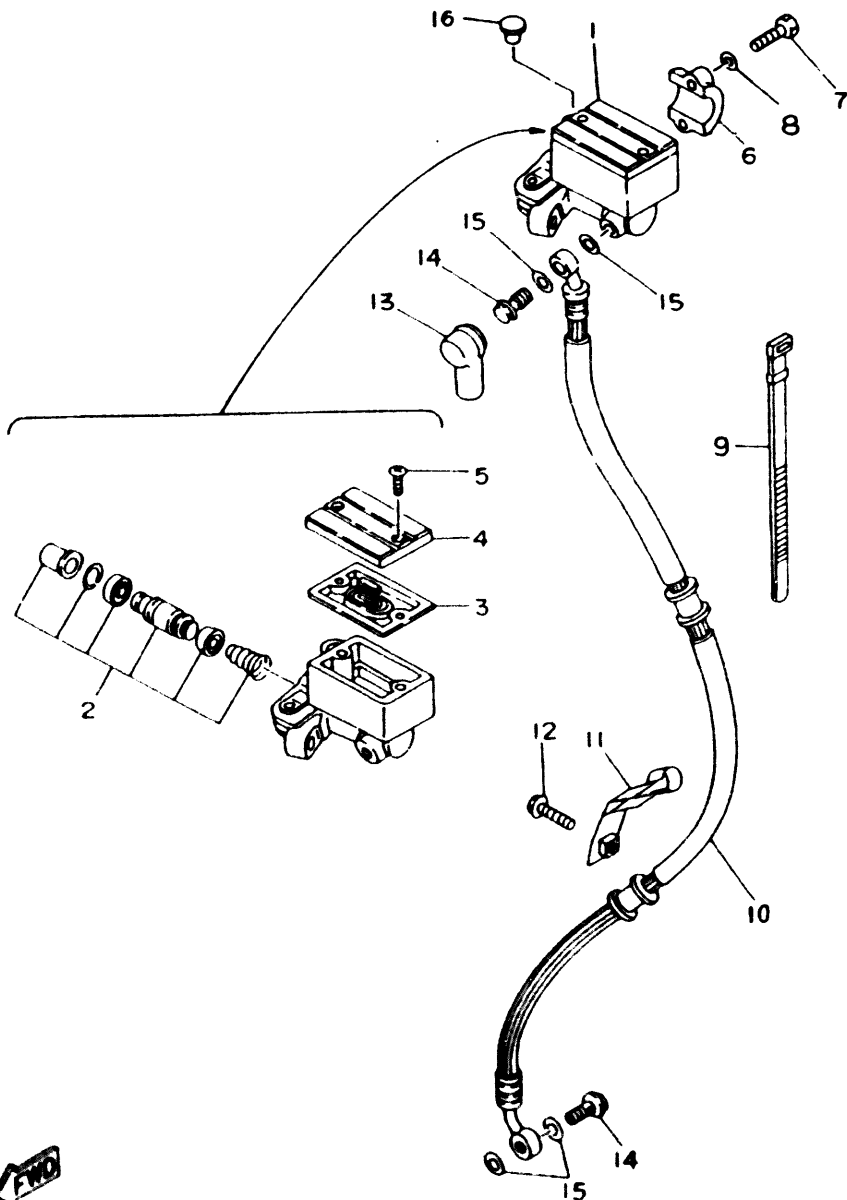

4VV2352-0290

FIG. 30 - ESTRIBERAS Y CABALLETE

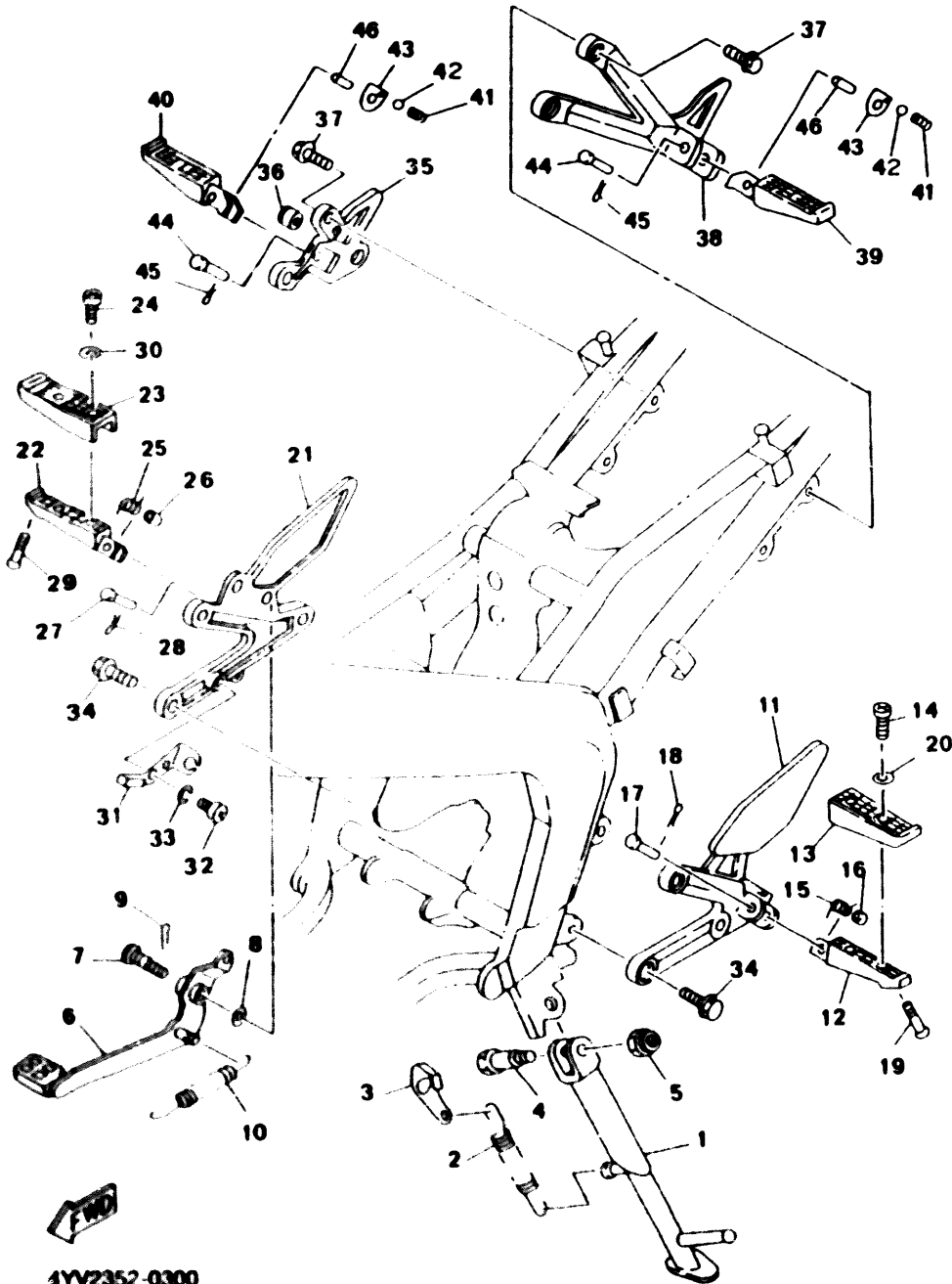

4YV2352-0300

REF. N.º	CODIGO N.º	DESCRIPCION	CANT.	OBSERVACION
1	2RN-F7311-00-33	CABALLETE LATERAL	1	UR YAMAHA BLACK
2	90506-26833	RESORTE DE TENSION	1	
3	4BA-F7315-00	CONEXION DE PUNTAL LATERAL	1	
4	90109-100E8	TORNILLO	1	
5	90185-10037	TUERCA DE AUTO-CIERRE	1	
6	4BA-F7211-10	PEDAL DE FRENO	1	
7	2YK-27261-00	EJE	1	
8	9290L-10200	ARANDELA PLANA	1	
9	90468-10050	PRESILLA	1	
10	90506-20843	RESORTE DE TENSION	1	
11	4BA-F7442-10-98	SOPORTE 2	1	UR LOW GLOSS BLACK
12	4BA-F7451-00	APOYAPIE	1	
13	4BA-F7413-00	CUBIERTA DE APOYAPIE	1	
14	90157-05079	TORNILLO CABEZA CONICA PLANA	2	
15	90508-20572	RESORTE DE TORSION	1	
16	90387-084N8	CASQUILLO	1	
17	91701-08042	PASADOR DE ABRAZADERA	1	
18	91401-25012	PASADOR DE CHAVETA	1	
19	90109-086F8	TORNILLO	1	
20	9290M-05200	ARANDELA PLANA	2	
21	4BA-F7443-10-98	SOPORTE 3	1	UR LOW GLOSS BLACK
22	4BA-F7461-00	APOYAPIE	1	
23	4BA-F7413-00	CUBIERTA DE APOYAPIE	1	
24	90157-05079	TORNILLO CABEZA CONICA PLANA	2	
25	90508-20572	RESORTE DE TORSION	1	
26	90387-084N8	CASQUILLO	1	
27	91701-08042	PASADOR DE ABRAZADERA	1	

FIG. 30 - ESTRIBERAS Y CABALLETE

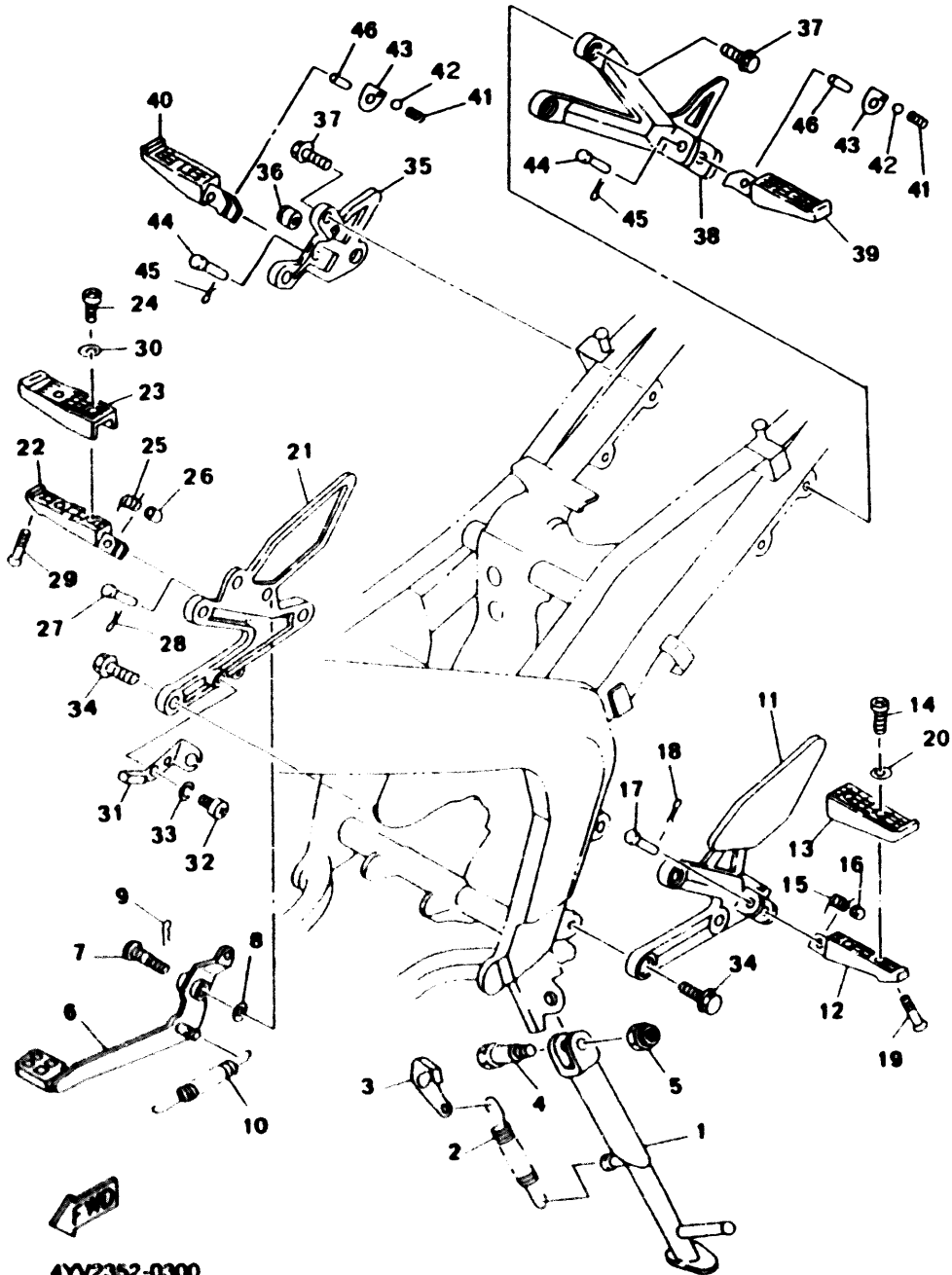

REF. N.º	CODIGO N.º	DESCRIPCION	CANT.	OBSERVACION
28	91401-25012	PASADOR DE CHAVETA	1	
29	90109-086F8	TORNILLO	1	
30	9290M-05200	ARANDELA PLANA	2	
31	4BA-F1441-00	SOPORTE INTERRUPTOR PARADA	1	
32	98502-06010	TORNILLO ALOMADO CON (X)	1	
33	9290N-06100	ARANDELA GROWER	1	
34	9581L-08020	TORNILLO HEXAGONAL CON VALONA	4	
35	4BA-F742L-10-98	MENSULA 5	1	UR LOW GLOSS BLACK
36	36Y-27414-00	AMORTIGUADOR DE APOYAPIE	1	
37	9581L-08020	TORNILLO HEXAGONAL CON VALONA	4	
38	4BA-F741L-10-98	SOPORTE 4	1	UR LOW GLOSS BLACK
39	4BA-F7431-00	REPOSAPIES TRASERO 1	1	
40	4BA-F7441-00	REPOSAPIES TRASERO 2	1	
41	90501-12743	MUELLE DE COMPRESION	2	
42	93501-04011	ESFERA	2	
43	4BA-F7437-00	ARANDELA ESPECIAL	2	
44	91701-06040	PASADOR	2	
45	91401-20012	CLAVIJA	2	
46	90387-064H8	CASQUILLO CON VALONA	2	

FIG. 31 - CILINDRO MAESTRO TRASERO

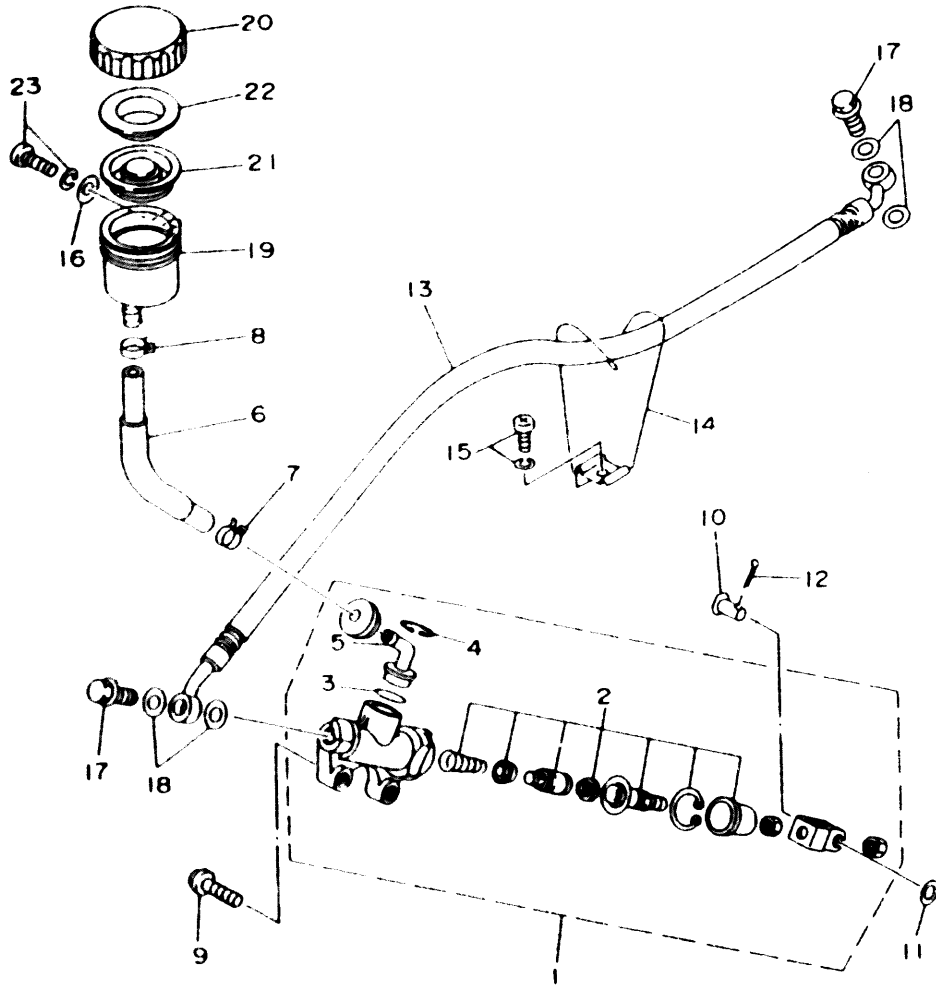

REF. N.º	CODIGO N.º	DESCRIPCION	CANT.	OBSERVACION
1	4BA-2583V-00	CILINDRO, MAESTRO TRASERO	1	
2	4BA-W0042-50	• JUEGO DE CILINDRO MAESTRO	1	
3	93210-15620	• ANILLO O	1	
4	2VN-25866-00	• PRESILLA REDONDA	1	
5	2VN-2582A-50	• CONECTOR	1	
6	4BA-25895-00	MANGUERA DE TANQUE DE RESERVA	1	
7	90467-11044	PRESILLA	1	
8	3PA-24356-00	PRESILLA DE TUBO 1	1	
9	90149-08814	TORNILLO	2	
10	90240-08124	PASADOR CON HOYO	1	
11	90201-08083	ARANDELA PLANA	1	
12	91401-16012	PASADOR DE CHAVETA	1	
13	4BA-25873-01	MANGUERA DE FRENO 2	1	
14	4BA-F5875-10	SOPORTE DE MANGUERA FRENO 1	1	
15	9850L-06016	TORNILLO ALOMADO CON (+)	1	
16	9290L-06100	ARANDELA GROWER	1	
17	90401-10159	PERNO DE UNIÓN	2	
18	90201-10118	ARANDELA PLANA	4	
19	31A-25894-01	TANQUE DE RESERVA	1	
20	2GU-25852-50	TAPA DE TANQUE DE RESERVA	1	
21	360-25854-00	DIAPHRAGMA TANQUE RESERVA	1	
22	2GU-25855-00	BUJE DE DIAFRAGMA	1	
23	9290L-06100	ARANDELA GROWER	1	
24	9850L-06020	TORNILLO ALOMADO CON (+)	1	
25	90201-08055	ARANDELA PLANA	1	



4V2352-0310

FIG. 32 - CUPULA CARENADO

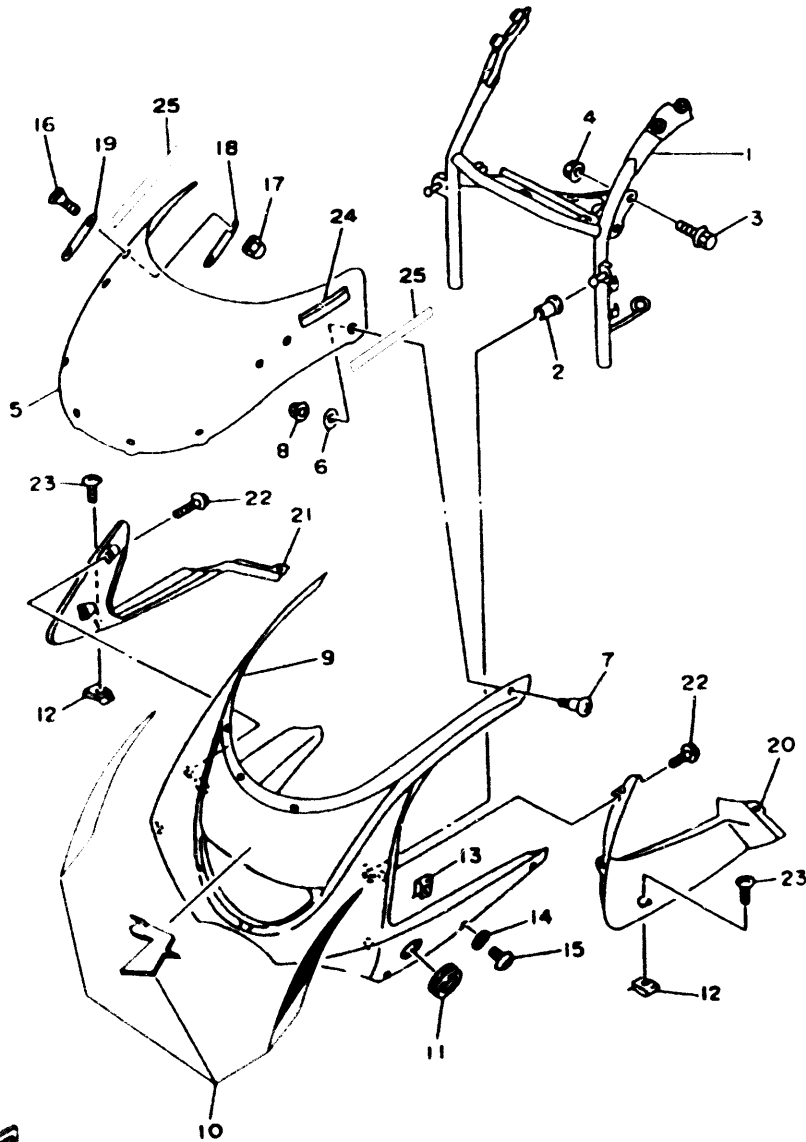

REF. N.º	CODIGO N.º	DESCRIPCION	CANT.	OBSERVACION
1	4BA-F8321-10	SOPORTE PROTECTOR PATA (MI)	1	
2	90480-12236	TAPÓN PROTECTOR	2	
3	9582L-08020	TORNILLO HEXAGONAL CON VALONA	2	
4	9570L-08500	TUERCA DE BRIDA	2	
5	4BA-F8381-00	PARABRISA	1	
6	4BA-F8215-00	ARANDELA ESPECIAL	6	
7	90149-05273	TORNILLO	6	
8	9570M-05500	TUERCA DE BRIDA	6	
9	4BA-X835G-R0-TR	CARROCERÍA DELANT. SUPERIOR 1	1	UR ROMANTIQUE ROUGE
10	4YV-F8390-R0	• EMBLEMA CARENADO COMP.	1	
11	90480-35394	TAPÓN PROTECTOR	2	
12	90183-04027	TUERCA DE RESORTE	2	
13	90183-05024	TUERCA DE RESORTE	6	
14	90202-05180	ARANDELA DE PLACA	6	
15	90110-05201	TORNILLO CABEZA HEXAGONAL	6	
16	9870M-06025	TORNILLO AVELLANADO CON (+)	4	
17	9530M-06800	TUERCA HEXAGONAL	4	
18	2RN-F8371-00	ESPONJA	2	
19	2RN-F8372-00	ESPONJA	2	
20	4BA-F835U-00	PANEL 1	1	
21	4BA-F835V-00	PANEL 2	1	
22	9770M-40512	TORNILLO PARA CHAPA ALOMADO	4	
23	9770M-40520	TORNILLO PARA CHAPA ALOMADO	2	
24	4BA-F835Y-00	ETIQUETA	1	
25	4YV-F8394-R0	EMBLEMA	2	WWW.CARLOS CHECA.COM

FIG. 33 - CARENADO

REF. N.º	CODIGO N.º	DESCRIPCION	CANT.	OBSERVACION
1	90149-05244	TORNILLO	2	
2	90202-05180	ARANDELA DE PLACA	2	
3	90179-05523	TUERCA	2	
4	4YV-X835J-40	CARROCERÍA DELANT. INFERIOR 1	1	UR ROMANTIQUE ROUGE
5	4YV-F8301-R0	• EMBLEMA	1	CHECA
6	4YV-F839J-R0	• EMBLEMA	1	TZR
7	5DU-F839H-00	• EMBLEMA	1	YAMAHA
8	4YV-F839H-R0	• EMBLEMA	1	ALPINESTAR
9	4YV-X835K-40	CARROCERÍA DELANT. INFERIOR 2	1	UR ROMANTIQUE ROUGE
10	4YV-F8303-R0	• EMBLEMA	1	CHECA
11	4YV-F839J-R0	• EMBLEMA	1	TZR
12	5DU-F839H-00	• EMBLEMA	1	YAMAHA
13	4YV-F839H-R0	• EMBLEMA	1	ALPINESTAR
14	4BA-2837J-00	AMORTIGUADOR	1	
15	4BA-F833K-00	MENSULA 13	2	
16	9580L-06012	TORNILLO HEXAGONAL CON VALONA	2	
17	4BA-F833M-00	SOPORTE 15	2	
18	9580L-06012	TORNILLO HEXAGONAL CON VALONA	2	
19	4BA-F833N-00	SOPORTE 16	1	
20	9580L-06012	TORNILLO HEXAGONAL CON VALONA	1	
21	90480-13398	TAPÓN PROTECTOR	5	
22	90387-067K6	CASQUILLO	5	
23	90110-06200	TORNILLO CABEZA HEXAGONAL	5	
24	4BA-F836K-20	PANEL 1	1	
25	2RN-F1518-00	SOPORTE DE CABLE	1	
26	4BA-2837K-00	AMORTIGUADOR 6	1	
27	90110-05201	TORNILLO CABEZA HEXAGONAL	2	

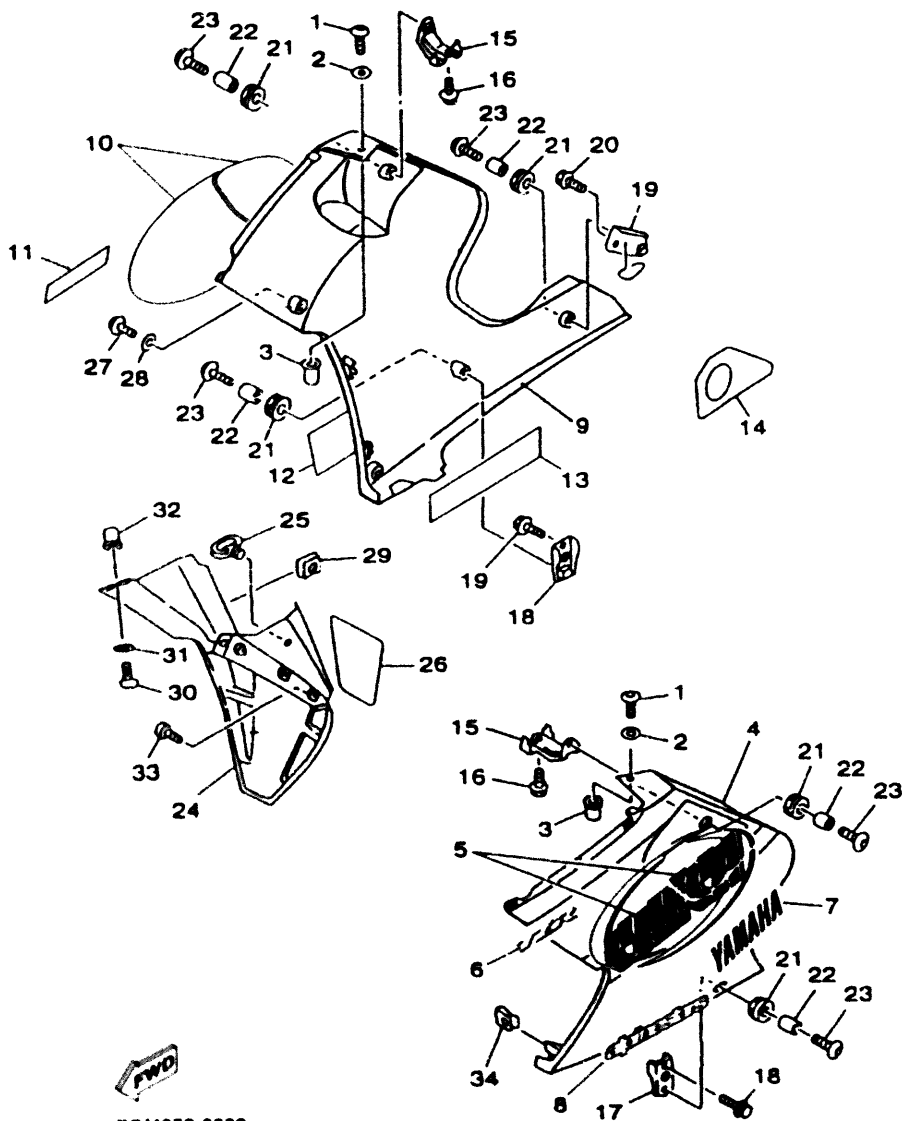

4YV4352-0330

FIG. 33 - CARENADO

REF. N.º	CODIGO N.º	DESCRIPCION	CANT.	OBSERVACION
28	90202-05180	ARANDELA DE PLACA	2	
29	90183-05024	TUERCA DE RESORTE	2	
30	90149-05299	TORNILLO	2	
31	90202-05180	ARANDELA DE PLACA	2	
32	90179-05523	TUERCA	2	
33	9770M-50614	TORNILLO PARA CHAPA ALOMADO	5	
34	90183-05042	TUERCA DE RESORTE	2	

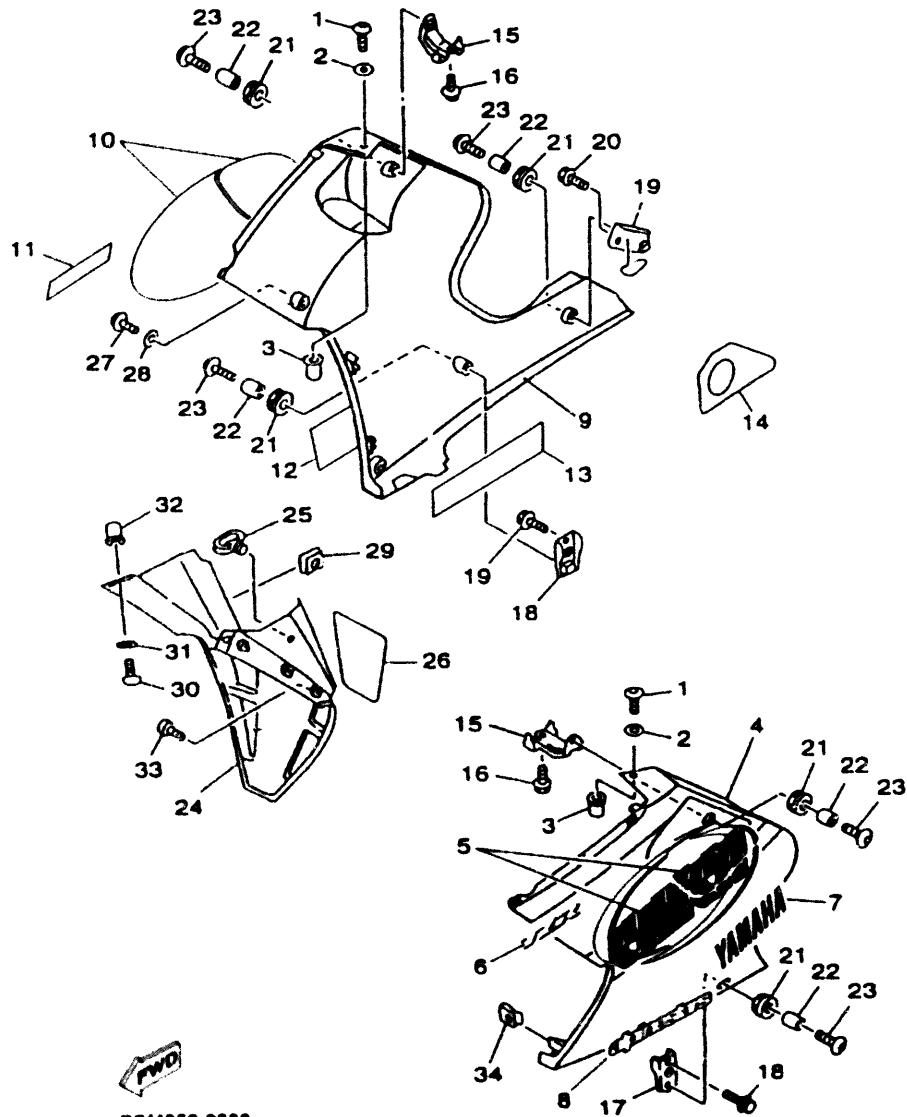

4YV4352-0330

FIG. 34 - GENERADOR

REF. N.º	CODIGO N.º	DESCRIPCION	CANT.	OBSERVACION
1	4YV-H5500-00	MAGNETO C.D.I. COMPLETO	1	
2	9131N-04010	TORNILLO ALLEN	3	
3	90170-10857	TUERCA	1	

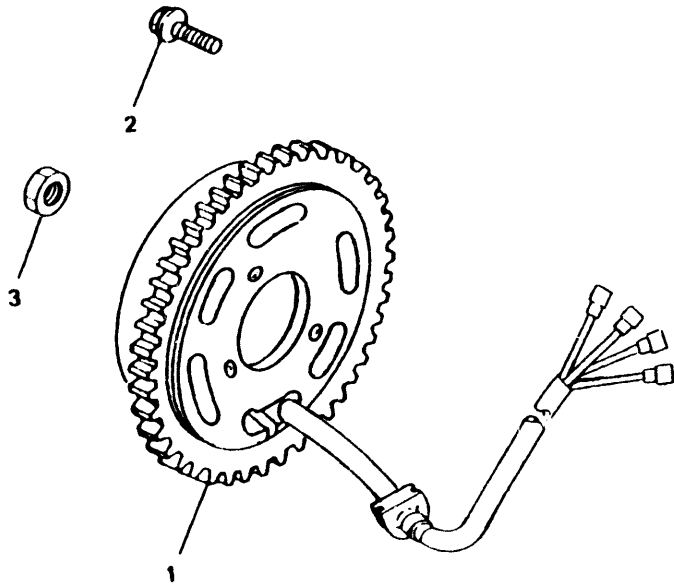

4YV2352-0340

FIG. 35 - INTERMITENTES

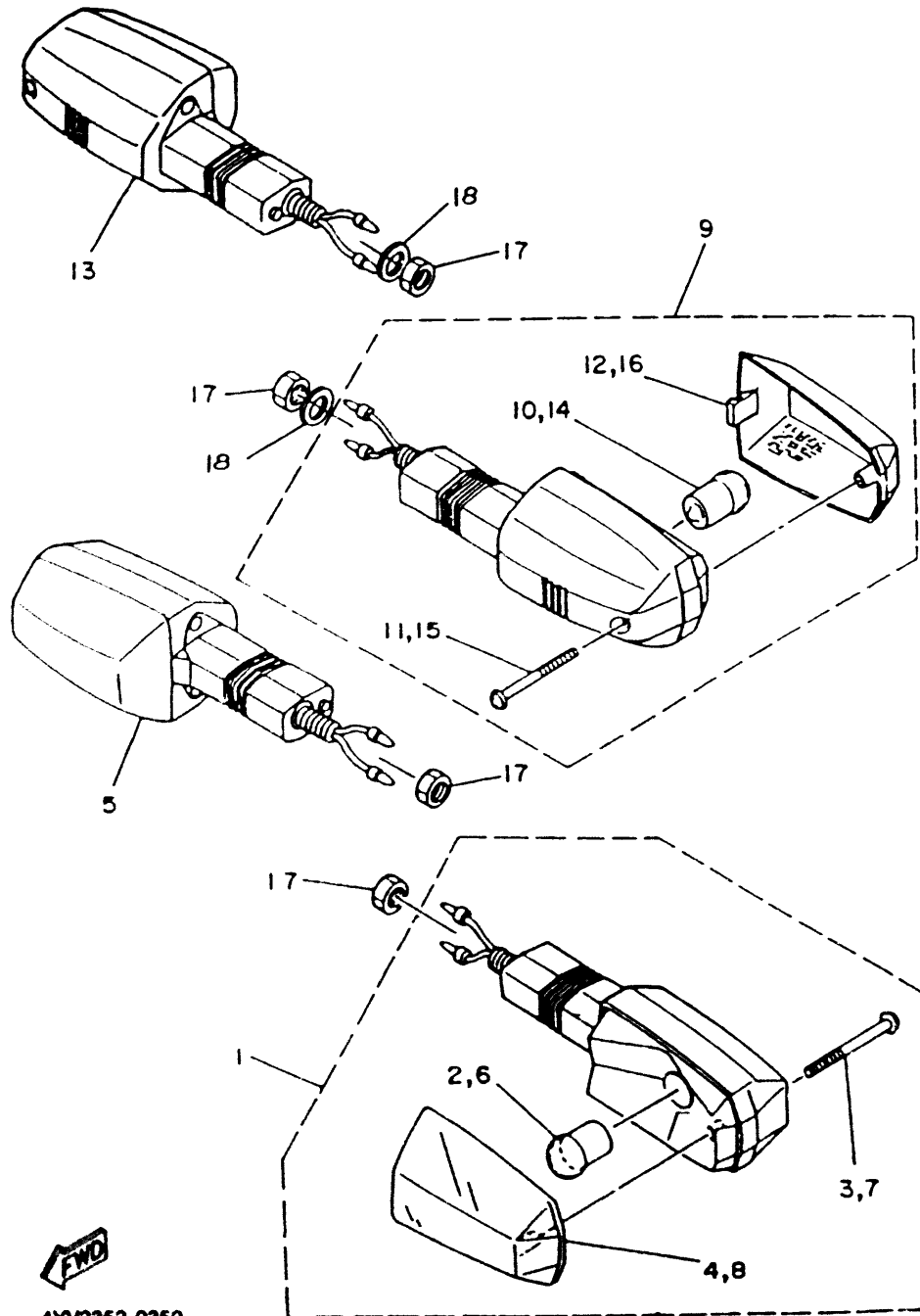

4YV2352-0350

REF. N.º	CODIGO N.º	DESCRIPCION	CANT.	OBSERVACION
1	4BA-H3310-00	DESTELLADOR DE LUZ DELANT.	1	
2	4BA-H3311-00	• BOMBILLA DE DESTELLADOR	1	
3	4BA-H3333-00	• TORNILLO ACCESORIO DE LENTE	1	
4	4BA-H3312-00	• LENTE DE DESTELLADOR	1	
5	4BA-H3320-00	DESTELLADOR DE LUZ DELANT.	1	
6	4BA-H3311-00	• BOMBILLA DE DESTELLADOR	1	
7	4BA-H3333-00	• TORNILLO ACCESORIO DE LENTE	1	
8	4BA-H3312-00	• LENTE DE DESTELLADOR	1	
9	4BA-H3330-00	DESTELLADOR DE LUZ TRAS.COMPL.	1	
10	4BA-H3311-00	• BOMBILLA DE DESTELLADOR	1	
11	4BA-H3333-00	• TORNILLO ACCESORIO DE LENTE	1	
12	4BA-H3312-00	• LENTE DE DESTELLADOR	1	
13	4BA-H3340-00	DESTELLADOR DE LUZ TRAS. COMPL.	1	
14	4BA-H3311-00	• BOMBILLA DE DESTELLADOR	1	
15	4BA-H3333-00	• TORNILLO ACCESORIO DE LENTE	1	
16	4BA-H3312-00	• LENTE DE DESTELLADOR	1	
17	9530M-12700	TUERCA HEXAGONAL	4	
18	90201-12814	ARANDELA PLANA	2	

CONTENIDO

MOTOR

Fig. 1 CILINDRO Y CULATA.....	B2
Fig. 2 GIGÜEÑAL. PISTÓN	B3
Fig. 3 BOMBA DE AGUA	B4
Fig. 4 RADIADOR	B5
Fig. 5 BOMBA DE ACEITE.....	B6
Fig. 6 ADMISIÓN	B7
Fig. 7 CARBURADOR	B8-B9
Fig. 8 TUBO DE ESCAPE.....	B10
Fig. 9 CÁRTER	B11
Fig. 10 CUBIERTA DE CÁRTER 1	B12
Fig. 11 EMBRAGUE	B13
Fig. 12 TRANSMISIÓN.....	B14
Fig. 13 ENGR. DE TACÓMETRO	B15
Fig. 14 LEVA DE CAMBIO. HORQ.	C2
Fig. 15 EJE DE CAMBIO. PEDAL.....	C3

CHASSIS

Fig. 16 BASTIDOR	C4
Fig. 17 GUARDABARROS.....	C5
Fig. 18 CUBIERTA LATERAL.....	C6-C7
Fig. 19 BRAZO TRASERO.....	C8
Fig. 20 DIRECCIÓN	C9
Fig. 21 HORQUILLA DELANTERA.....	C10-C-11
Fig. 22 DEPÓSITO DE COMBUSTIBLE	C12-C-13
Fig. 23 ASIENTO	C14
Fig. 24 RUEDA DELANTERA	C15

Fig. 25 PINZA FRENO DELANTERO.....	D2
Fig. 26 RUEDA TRASERA.....	D3-D4
Fig. 27 PINZA FRENO TRASERO	D5
Fig. 28 MANILLAR Y CABLES	D6
Fig. 29 BOMBA DE FRENO DELANTERO	D7
Fig. 30 ESTRIBERAS Y CABALLETE.....	D8-D9
Fig. 31 CILINDRO MAESTRO TRASERO.....	D10
Fig. 32 CÚPULA CARENADO	D11
Fig. 33 CARENADO	D12-D13
Fig. 34 GENERADOR.....	D14
Fig. 35 INTERMITENTES.....	D15
Fig. 36 PANEL DE C.KMS. Y TESTIGOS.....	E2
Fig. 37 FARO DELANTERO.....	E3
Fig. 38 PILOTO TRASERO.....	E4
Fig. 39 CONMUTADORES Y MANETAS	E5
Fig. 40 GRUPO ELÉCTRICO 1.....	E6-E7

ÍNDICE

ÍNDICE NUMÉRICO	M1 ~ M3
-----------------------	---------

CONTENIDO

MOTOR

Fig. 1 CILINDRO Y CULATA.....	B2
Fig. 2 GIGÜEÑAL. PISTÓN.....	B3
Fig. 3 BOMBA DE AGUA.....	B4
Fig. 4 RADIADOR.....	B5
Fig. 5 BOMBA DE ACEITE.....	B6
Fig. 6 ADMISIÓN.....	B7
Fig. 7 CARBURADOR.....	B8-B9
Fig. 8 TUBO DE ESCAPE.....	B10
Fig. 9 CÁRTER.....	B11
Fig. 10 CUBIERTA DE CÁRTER 1.....	B12
Fig. 11 EMBRAGUE.....	B13
Fig. 12 TRANSMISIÓN.....	B14
Fig. 13 ENGR. DE TACÓMETRO.....	B15
Fig. 14 LEVA DE CAMBIO. HORQ.....	C2
Fig. 15 EJE DE CAMBIO. PEDAL.....	C3

CHASSIS

Fig. 16 BASTIDOR.....	C4
Fig. 17 GUARDABARROS.....	C5
Fig. 18 CUBIERTA LATERAL.....	C6-C7
Fig. 19 BRAZO TRASERO.....	C8
Fig. 20 DIRECCIÓN.....	C9
Fig. 21 HORQUILLA DELANTERA.....	C10-C-11
Fig. 22 DEPÓSITO DE COMBUSTIBLE.....	C12-C-13
Fig. 23 ASIENTO.....	C14
Fig. 24 RUEDA DELANTERA.....	C15

Fig. 25 PINZA FRENO DELANTERO.....	D2
Fig. 26 RUEDA TRASERA.....	D3-D4
Fig. 27 PINZA FRENO TRASERO.....	D5
Fig. 28 MANILLAR Y CABLES.....	D6
Fig. 29 BOMBA DE FRENO DELANTERO.....	D7
Fig. 30 ESTRIBERAS Y CABALLETE.....	D8-D9
Fig. 31 CILINDRO MAESTRO TRASERO.....	D10
Fig. 32 CÚPULA CARENADO.....	D11
Fig. 33 CARENADO.....	D12-D13
Fig. 34 GENERADOR.....	D14
Fig. 35 INTERMITENTES.....	D15
Fig. 36 PANEL DE C.KMS. Y TESTIGOS.....	E2
Fig. 37 FARO DELANTERO.....	E3
Fig. 38 PILOTO TRASERO.....	E4
Fig. 39 CONMUTADORES Y MANETAS.....	E5
Fig. 40 GRUPO ELÉCTRICO 1.....	E6-E7

ÍNDICE

ÍNDICE NUMÉRICO.....	M1 ~ M3
----------------------	---------

FIG. 36 - PANEL DE CUENTA KMS Y TESTIGOS

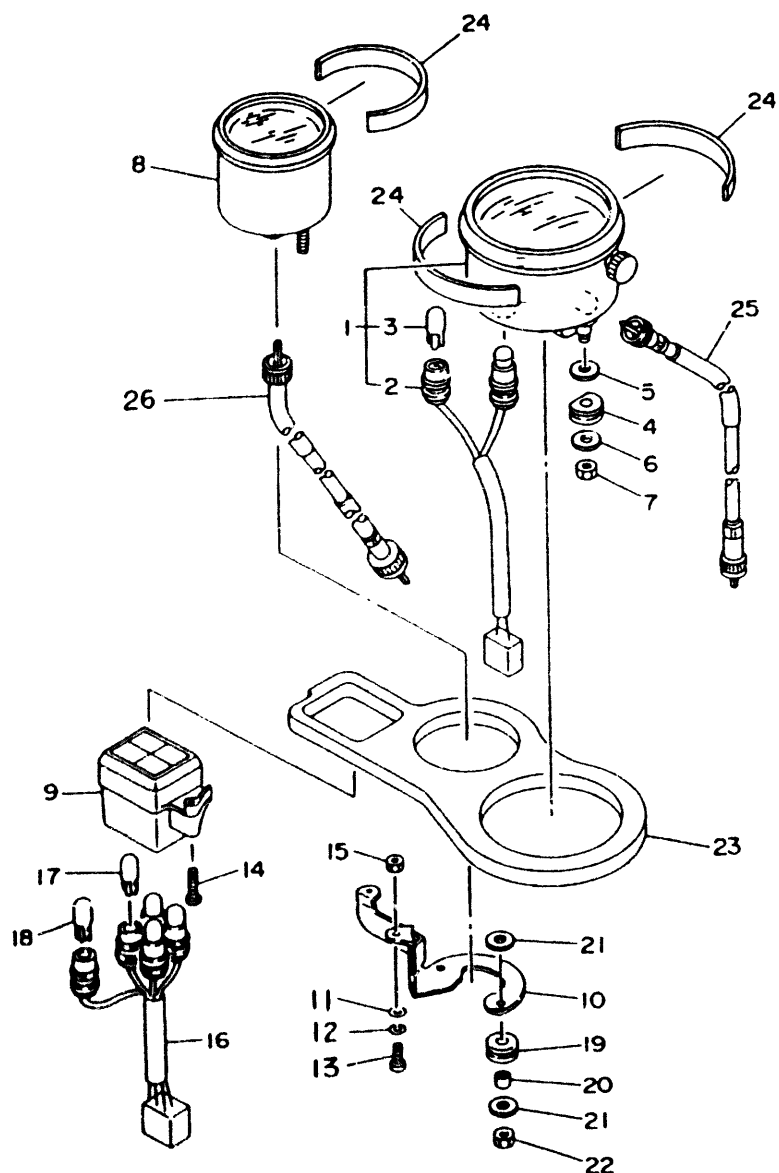

4YV2352-0360

REF. N.º	CODIGO N.º	DESCRIPCION	CANT.	OBSERVACION
1	4BA-83580-00	VELOCIMETRO COMPLETO	1	
2	4BA-83509-00	ENCASTRE DE CABLE COMPLETO	1	
3	1YT-83517-00	LAMPARA	2	
4	4BA-H3533-00	ANILLO PROTECTOR	2	
5	90201-07081	ARANDELA PLANA	2	
6	90201-05031	ARANDELA PLANA	2	
7	95301-05600	TUERCA HEXAGONAL	2	
3	4YV-83540-00	TACOMETRO COMPLETO	1	
9	3TU-83530-00	LAMPARA PILOTO COMPLETA	1	
10	3TU-83519-00	SOPORTE DE MEDIDOR	1	
11	92907-06300	ARANDELA	1	
12	92907-03100	ARANDELA	1	
13	98507-03012	TORNILLO ALOMADO CON (X)	1	
14	90164-03027	TORNILLO ROSCA HEMBRA	1	
15	95307-05600	TUERCA HEXAGONAL	2	
16	3TU-8350L-00	ENCASTRE COMPLETO	1	
17	4G1-84744-00	BOMBILLA	4	
18	1YT-83517-00	LAMPARA	1	
19	90480-13428	TAPON PROTECTOR	2	
20	90387-052M2	CASQUILLO	2	
21	90201-05031	ARANDELA PLANA	4	
22	95301-05600	TUERCA HEXAGONAL	2	
23	4BA-H3611-00	PANEL DE MEDIDOR	1	
24	4BA-H2121-00	BASE DE BATERIA	3	
25	4YV-H3550-00	CABLE DE VELOCIMETRO COMPLETO	1	
26	4BA-83560-01	CABLE DE TACOMETRO COMPLETO	1	

FIG. 37 - FARO DELANTERO

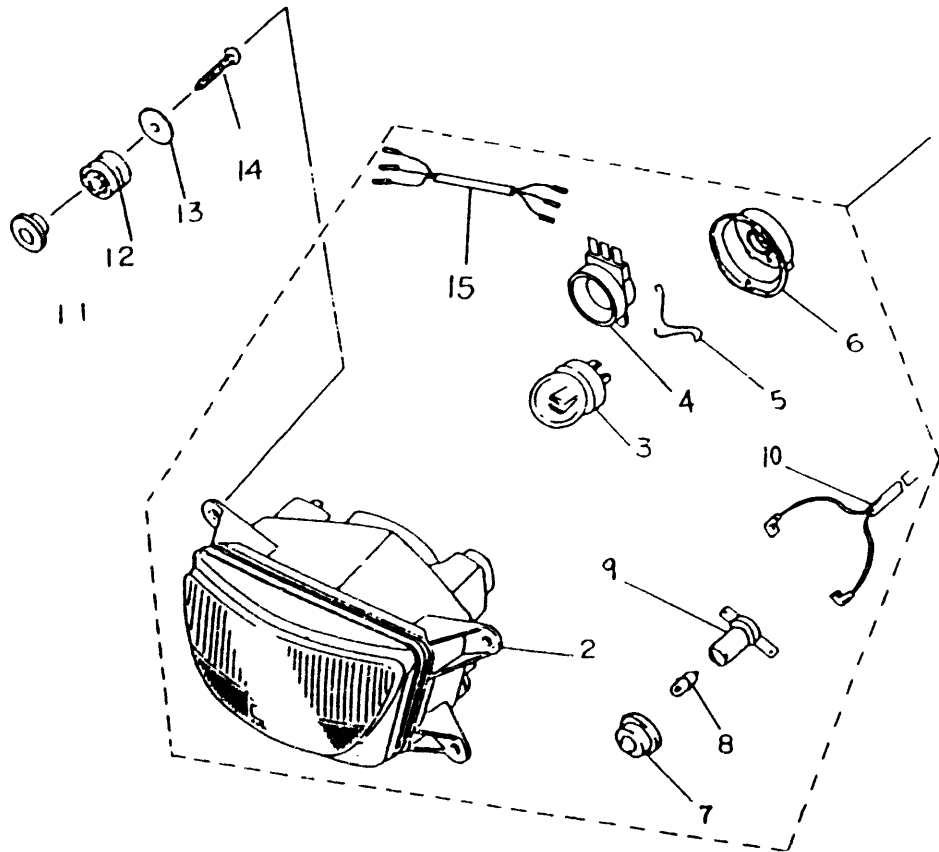

REF. N.º	CODIGO N.º	DESCRIPCION	CANT.	OBSERVACION
1	5DU-H4300-00	FARO DELANTERO COMPLETO	1	
2	5DU-H4310-00	• UNIDAD DE FARO DELANTERO	1	
3	5AD-H4314-00	• BOMBILLA DE FARO DELANTERO	1	
4	5DU-H4112-00	• PORTALAMPARAS	1	
5	3WG-H4324-00	• MUELLE SUJEC. PORTALAMPARAS	1	
6	5DU-H4197-00	• TAPA PORTALAMPARAS	1	
7	4BA-H4152-10	• CASQUILLO DE GOMA	1	
8	4BA-H4347-00	• LAMPARA	1	
9	4BA-H4146-00	• PORTALAMPARA	1	
10	4BA-H4312-00	• INSTALACION ELECTRICA	1	
11	5DU-H4359-00	• SUPLEMENTO INST. ELECTRICA	1	
12	4BA-H4152-00	GOMA AMORTIGUADORA	4	
13	90201-064H0	ARANDELA PLANA	4	
14	97702-50022	TORNILLO	4	
15	90387-065J6	CASQUILLO	4	



4YV2352-0370

FIG. 38 - PILOTO TRASERO

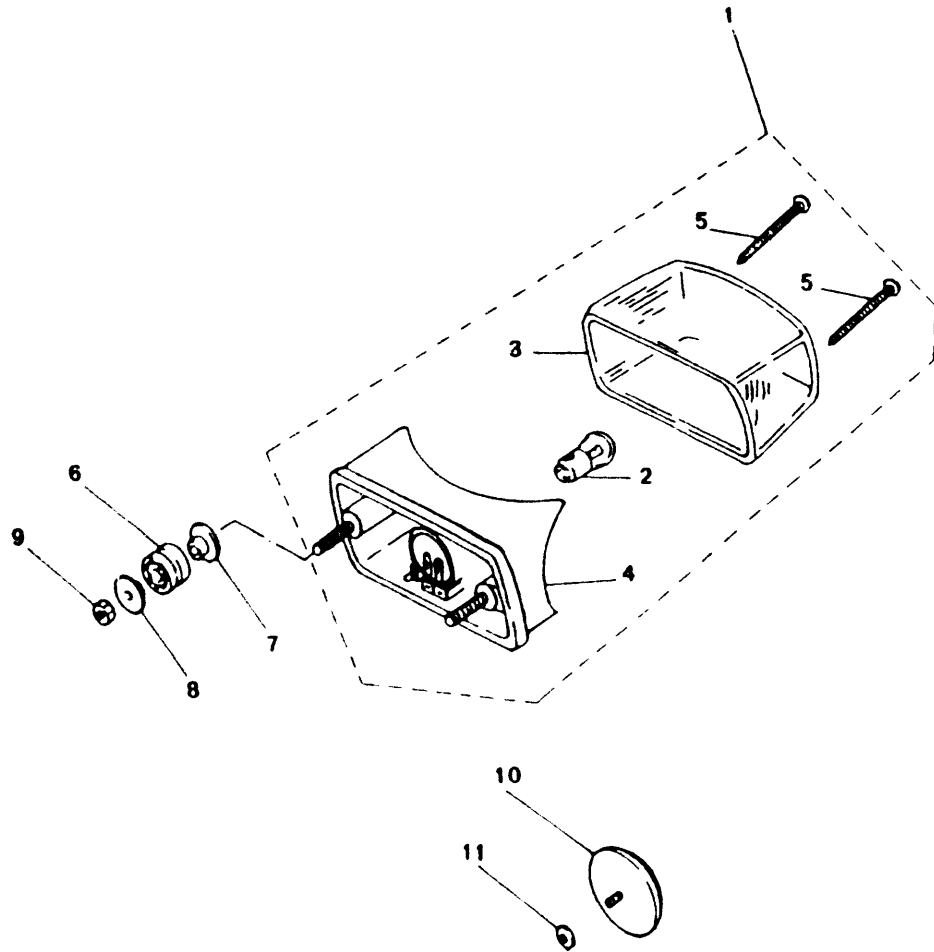

REF. N.º	CODIGO N.º	DESCRIPCION	CANT.	OBSERVACION
1	4BA-H4710-00	CONJT. FARO TRASERO	1	
2	4BA-H4714-00	• BOMBILLA	1	
3	4BA-H4721-00	• LENTE DE PILOTO TRASERO	1	
4	4BA-H4720-00	• BASE DE LUZ TRASERA	1	
5	4BA-H4724-00	• TORNILLO ACCESORIO DE LENTE	2	
6	90480-18276	TAPON PROTECTOR	2	
7	90387-060A7	CASQUILLO	2	
8	90201-060A3	ARANDELA PLANA	2	
9	95302-06600	TUERCA HEXAGONAL	2	
10	4BA-H5130-00	REFLECTOR TRASERO COMPLETO	1	
11	9570M-05500	TUERCA DE BRIDA	1	



4V2352-0380

FIG. 39 - CONMUTADORES Y MANETAS

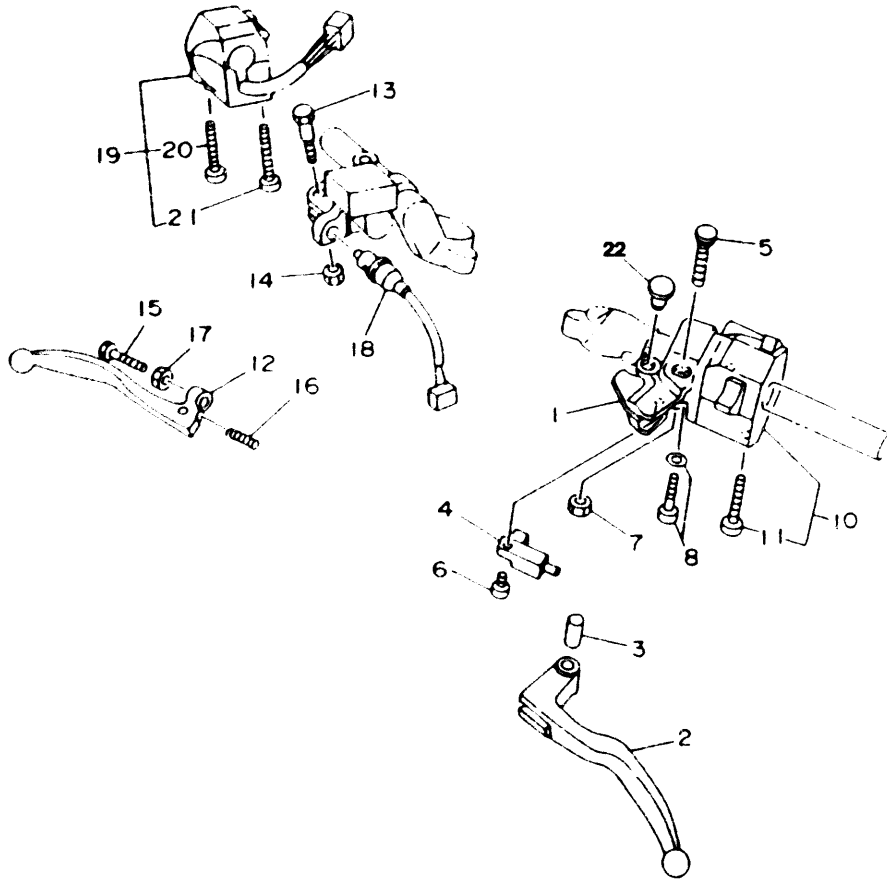

REF. N.º	CODIGO N.º	DESCRIPCION	CANT.	OBSERVACION
1	29L-82911-01	SOPORTE DE LEVA 1	1	
2	3H3-83912-00	PALANCA 1	1	
3	31A-83913-00	COLLAR DE PALANCA 1	1	
4	31A-82917-00	INTERRUPTOR	1	
5	31A-83945-00	PERNO DE PALANCA	1	
6	98707-03008	TORNILLO AVELLANADO CON (X)	1	
7	95607-06100	TUERCA DE AUTO-CIERRE	1	
8	9700M-06025	TORNILLO HEXAGONAL	1	
9	9290M-06600	ARANDELA PLANA	1	
10	4YV-83972-00	INTERRUPTOR DE MANIJA 4	1	
11	9850M-05035	• TORNILLO ALOMADO CON (X)	2	
12	3GM-83922-00	PALANCA 2	1	
13	90109-06577	TORNILLO	1	
14	9560M-06100	TUERCA U	1	
15	90149-06153	TORNILLO	1	
16	90501-10312	RESORTE DE COMPRESION	1	
17	90170-06010	TUERCA	1	
18	3WP-83890-00	INTERRUP.PARADA DELANTERO	1	
19	4YV-83963-00	INTERRUPTOR DE MANIJA 3	1	
20	98506-05040	• TORNILLO ALOMADO CON (X)	1	
21	98506-05045	• TORNILLO ALOMADO CON (X)	1	
22	90338-09800	TAPON	1	



4YV2352-0390

FIG. 40 - GRUPO ELECTRICO 1

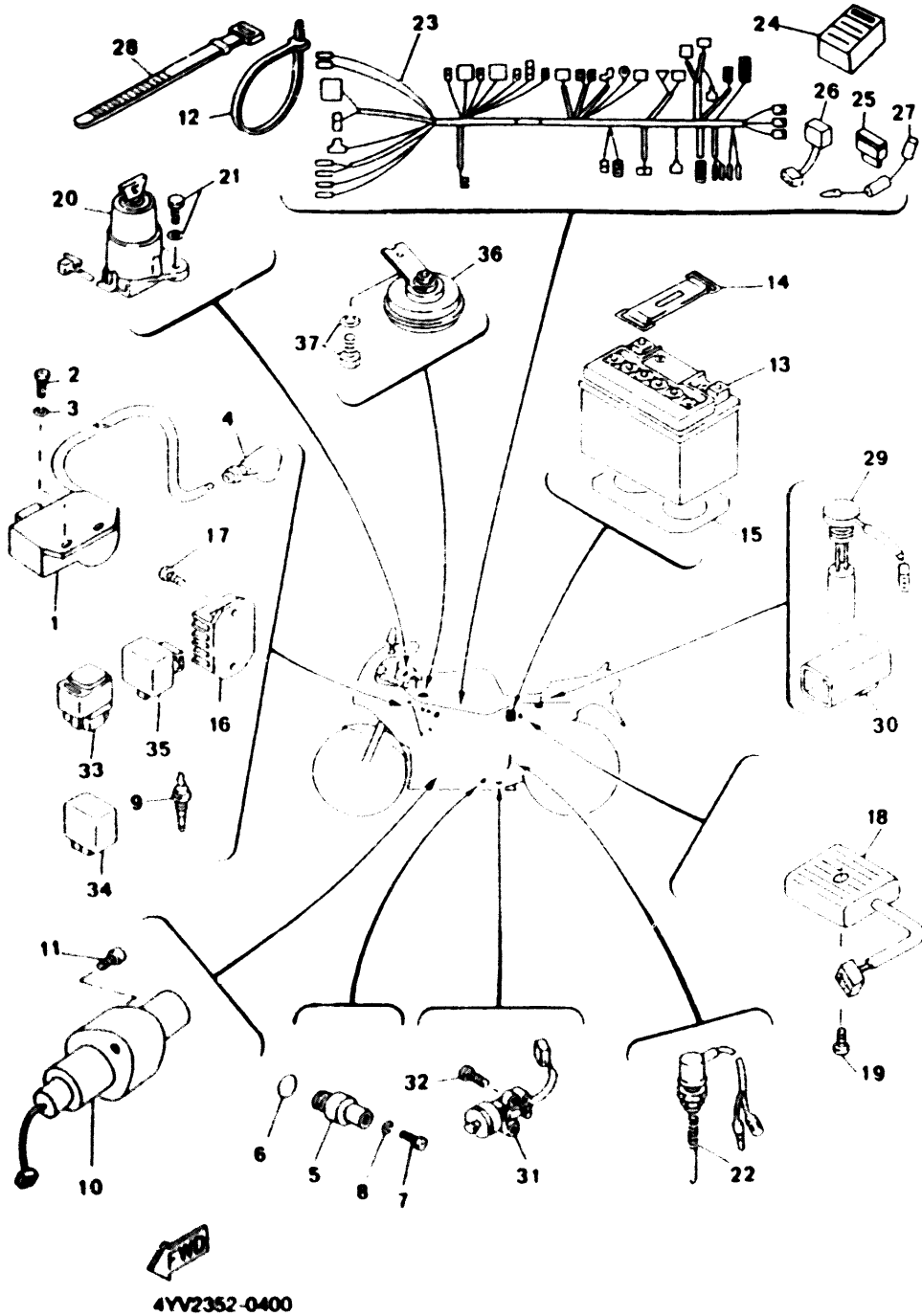

4YV2352-0400

REF. N.º	CODIGO N.º	DESCRIPCION	CANT.	OBSERVACION
1	4YV-H5540-00	UNIDAD C.D.I. COMPLETA	1	
2	9131L-06020	TORNILLO ALLEN	2	
3	9290N-06600	ARANDELA PLANA	2	
4	2JW-H2370-00	CAPUCHON DE BUJIA COMPLETO	1	
5	3NC-H2540-00	INTERRUPTOR NEUTRAL COMPL.	1	
6	90430-09824	JUNTA	1	
7	9850L-04006	TORNILLO ALOMADO CON (X)	1	
8	90205-04802	ARANDELA DENTADA	1	
9	11H-82560-00	INTER. DE NIVEL ACEITE	1	
10	4YV-H1800 10	MOTOR DE ARRANQUE COMPLETO	1	
11	90110-06X23	TORNILLO ALLEN	2	
12	90464-13804	BRIDA	6	
13	3UC-82100-11	BATERIA COMPLETA	1	
14	4BA-H2131-00	BANDA DE BATERIA	1	
15	4BA-H2122-00	ASIENTO DE BATERIA	1	
16	4YV-H1910-00	REGULADOR DE VOLTAJE COMPLETO	1	
17	9700L-06030	TORNILLO HEXAGONAL CON VALONA	1	
18	4ML-81970-00	RECTIFICADOR COMPLETO	1	
19	9582M-06020	TORNILLO HEXAGONAL CON VALONA	1	
20	3TU-82501-00	CERRADURA PUESTA EN MARCHA C.	1	
21	9750N-06516	TORNILLO HEX. CON ARANDELA	2	
22	4BA H2530-00	INTERRUPTOR DE PARADA COMPLETO	1	
23	4YV-H2590-00	INSTALACION ELECTRICA COMPLETA	1	
24	4BA-H2155-00	ABRAZADERA	1	
25	4BA-H2151-00	FUSIBLE	1	
26	4BA-H5370-00	RESISTENCIA COMPLETA	1	
27	4YV-H1980-00	DIODO	2	

FIG. 40 - EQUIPO ELECTRICO 1

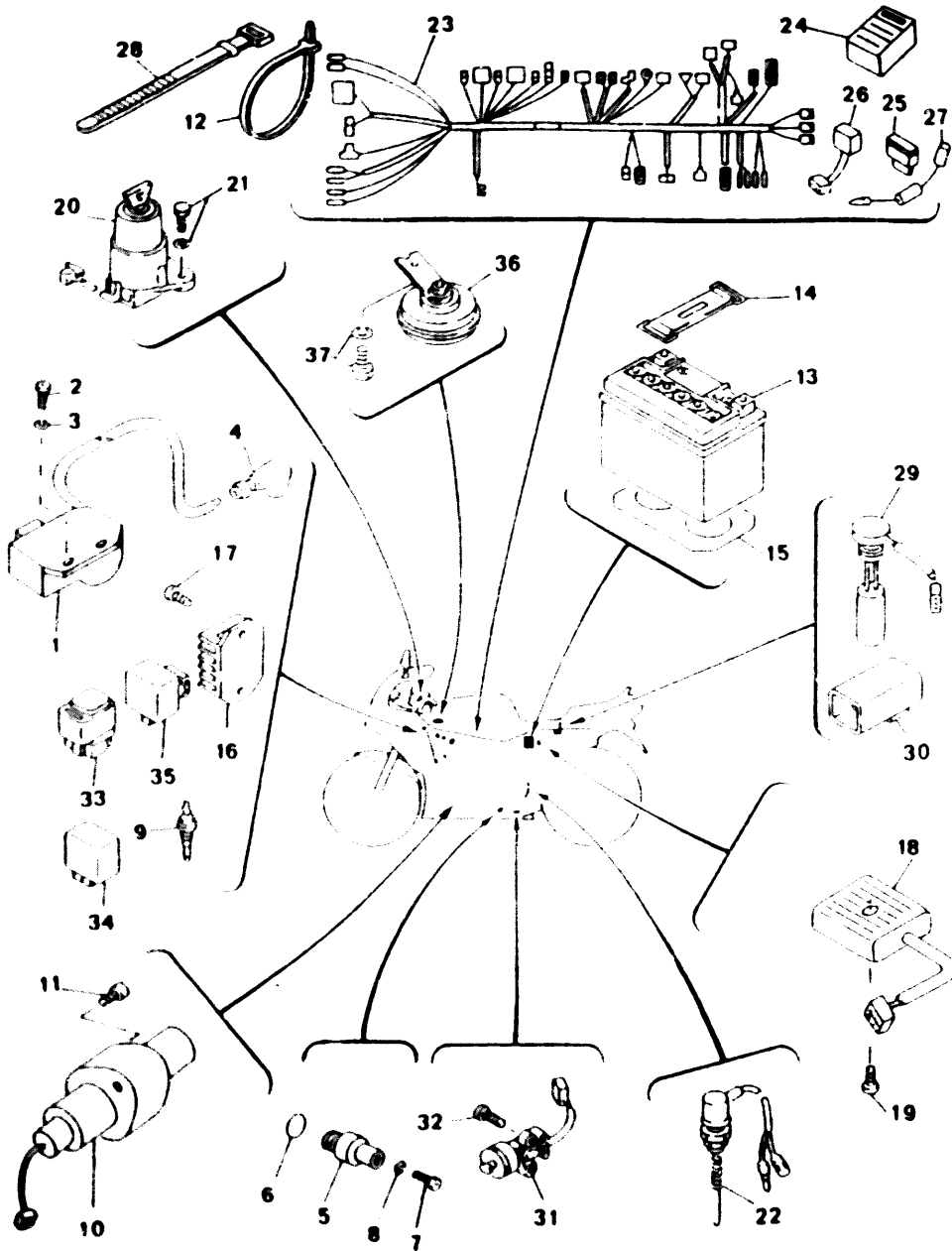

REF. N.º	CODIGO N.º	DESCRIPCION	CANT.	OBSERVACION
----------	------------	-------------	-------	-------------

28	5T8-H3936-10	BANDA	1	
29	3MA-85720-12	MEDIDOR DE NIVEL DE ACEITE	1	
30	2XX-81940-00	INTERRUPTOR DE ARRANQUE COMPL	1	
31	3LD-82566-50	INTERRUPTOR	1	
32	90110-05822	TORNILLO CABEZA HEXAGONAL	2	
33	25G-81950-01	RELE COMPLETO	1	
34	3GM-81950-00	RELE COMPLETO	1	
35	29G-83350-20	RELE DE DESTELLADOR COMPLETO	1	
36	4MJ-H3371-00	CLAXON	1	
37	9750M-06412	TORNILLO HEX. CON ARANDELA	1	

FWD
4YV2352-0400

CONTENIDO

MOTOR

Fig. 1 CILINDRO Y CULATA	B2
Fig. 2 GIGÜEÑAL. PISTÓN	B3
Fig. 3 BOMBA DE AGUA	B4
Fig. 4 RADIADOR	B5
Fig. 5 BOMBA DE ACEITE	B6
Fig. 6 ADMISIÓN	B7
Fig. 7 CARBURADOR	B8-B9
Fig. 8 TUBO DE ESCAPE	B10
Fig. 9 CÁRTER	B11
Fig. 10 CUBIERTA DE CÁRTER 1	B12
Fig. 11 EMBRAGUE	B13
Fig. 12 TRANSMISIÓN	B14
Fig. 13 ENGR. DE TACÓMETRO	B15
Fig. 14 LEVA DE CAMBIO. HORQ.	C2
Fig. 15 EJE DE CAMBIO. PEDAL	C3

CHASSIS

Fig. 16 BASTIDOR	C4
Fig. 17 GUARDABARROS	C5
Fig. 18 CUBIERTA LATERAL	C6-C7
Fig. 19 BRAZO TRASERO	C8
Fig. 20 DIRECCIÓN	C9
Fig. 21 HORQUILLA DELANTERA	C10-C-11
Fig. 22 DEPÓSITO DE COMBUSTIBLE	C12-C-13
Fig. 23 ASIENTO	C14
Fig. 24 RUEDA DELANTERA	C15

Fig. 25 PINZA FRENO DELANTERO	D2
Fig. 26 RUEDA TRASERA	D3-D4
Fig. 27 PINZA FRENO TRASERO	D5
Fig. 28 MANILLAR Y CABLES	D6
Fig. 29 BOMBA DE FRENO DELANTERO	D7
Fig. 30 ESTRIBERAS Y CABALLETE	D8-D9
Fig. 31 CILINDRO MAESTRO TRASERO	D10
Fig. 32 CÚPULA CARENADO	D11
Fig. 33 CARENADO	D12-D13
Fig. 34 GENERADOR	D14
Fig. 35 INTERMITENTES	D15
Fig. 36 PANEL DE C.KMS. Y TESTIGOS	E2
Fig. 37 FARO DELANTERO	E3
Fig. 38 PILOTO TRASERO	E4
Fig. 39 CONMUTADORES Y MANETAS	E5
Fig. 40 GRUPO ELÉCTRICO 1	E6-E7

ÍNDICE

ÍNDICE NUMÉRICO	M1 ~ M3
-----------------------	---------

CODIGO N.º	REF. NO.	CODIGO N.º	REF. NO.	CODIGO N.º	REF. NO.	CODIGO N.º	REF. NO.	CODIGO N.º	REF. NO.	CODIGO N.º	REF. NO.
31A-14477-00	C5	3LD-25924-00	D2	4YV-E 454-00	B3	4SB-E4331-00	B8	4YV-E6381-00	B13	3WG-F1771-00	C6
4L0-17818-00	B15	2GV-25926-00	D5	4YV-E1531-00	B3	4SB-E4335-00	B8	4YV-E7121-00	B14	4YV-F1781-R0	C6
4R8-21308-00	C14	3LD-25934-01	D2	4YV-E1536-00	B3	5AD-E4336-00	B8	4YV-E7131-00	B14	4YV-F1781-R0	C6
29N-22141-00	C8	34X-25937-00	D5	4YV-E1603-00	B3	5BV-E4341-00	B8	4YV-E7151-00	B14	4YV-F1782-R0	C6
4BA-22210-01	C8	5R2-25937-00	D5	4YV-E1604-00	B3	4SB-E4342-00	B8	4YV-E7161-00	B14	4YV-F1782-R0	C6
1GU-23125-00	C10	1UY-25937-51	D2	4YV-E1605-00	B3	5DU-E4343-00	B8	4YV-E7211-00	B14	2RN-F1815-00	C6
1GU-23125-00	C10	2YK-27261-00	D8	4YV-E1631-00	B3	5DU-E4344-00	B8	4YV-E7221-00	B14	4BA-F1871-00	C6
1GU-23144-00	C10	36Y-27414-00	D9	4YV-E1633-00	B3	5DU-E4368-00	B8	4YV-E7231-00	B14	4YV-F2110-00-98	C8
1GU-23144-00	C11	4BA-2837J-00	D12	4YV-E1635-00	B3	5DU-E4369-00	B8	4YV-E7241-00	B14	2RN-F2128-00	C8
4BA-23171-01	C10	4BA-2837K-00	D12	4YV-E1636-00	B3	4SB-E4371-00	B8	4YV-E7251-00	B14	4YV-F2151-00	C8
4BA-23171-01	C10	2XX-81940-00	E7	4YV-E1651-00	B3	4SB-E4377-00	B8	4YV-E7261-00	B14	4BA-F2184-00	C8
156-23411-00	C11	3GM-81950-00	E7	4YV-E2411-00	B2	4SB-E4385-00	B8	4YV-E7411-00	B14	4BA-F2311-00	C8
183-23411-00	C9	25G-81950-01	E7	3NC-E2422-00	B4	4SB-E4386-00	B8	4YV-E7421-00	B14	4BA-F3102-00-98	C10
156-23412-00	C9	4ML-81970-00	E6	3NC-E2428-01	B4	5DU-E4392-00	B8	5BX-E7460-00	B14	4BA-F3103-00-98	C10
183-23412-00	C9	3UC-82100-11	E6	2RN-E2437-00	B5	5DU-E4396-00	B8	3NC-E7811-00	B15	2RN-F3110-00	C10
3PA-24356-00	D10	3TU-82501-00	E6	2VR-E2450-00	B4	2RN-E4411-00	B7	4YV-E7831-00	B15	2RN-F3110-00	C10
23F-24500-01	C12	11H-82560-00	E6	3NC-E2459-00	B4	2RN-E4412-00	B7	4YV-E7841-00	B15	2RN-F3111-00	C10
4X8-24512-00	C12	3LD-82566-50	E7	4BA-E2460-00	B5	4BA-E4415-00	B7	4YV-E7861-00	B15	2RN-F3111-00	C11
3AJ-24523-00	C12	29L-82911-01	E5	2RN-E2462-00	B5	4BA-E4437-00	B7	4YV-E8101-00	C3	4BA-F3126-00-98	C10
3AJ-24534-00	C12	31A-82917-00	E5	4YV-E2481-10	B5	2RN-E4451-00	B7	4BA-E8111-10	C3	4BA-F3136-00-98	C10
4FU-24610-00	C12	29G-83350-20	E7	4YV-E2482-00	B2	2RN-E4452-00	B7	4YV-E8112-10	C3	4BA-F3141-00	C10
47X-24708-00	C14	4BA-83509-00	E2	4YV-E2483-00	B5	4YV-E4453-10	B7	5T8-E8113-00	C3	4BA-F3141-00	C11
51Y-25181-00	C15	3TU-8350L-00	E2	4YV-E2486-00	B2	4BA-E4472-00	B7	4YV-E8115-10	C3	2RN-F3151-00	C10
2L4-25190-20	C15	1YT-83517-00	E2	4YV-E2572-00	B2	4YV-E4710-10	B10	4YV-E8141-00	C3	2RN-F3151-00	C10
4L1-25364-00	D3	1YT-83517-00	E2	4YV-E2582-00	B4	4YV-E5128-00	B11	21L-E8154-00	C3	2RN-F3154-00	C10
4BA-25381-00	D3	3TU-83519-00	E2	5BK-E3100-00	B6	4YV-E5149-00	C3	4YV-E8511-00	C2	2RN-F3154-00	C11
4BA-2580U-01	D2	3TU-83530-00	E2	4YV-E316F-10	B6	4YV-E5150-10	B11	4YV-E8512-00	C2	2RN-F3156-00	C10
4BA-2580W-00	D5	4YV-83540-00	E2	4YV-E316G-10	B6	4YV-E5363-00	B12	4YV-E8513-C0	C2	2RN-F3156-00	C10
3FY-25827-00	D5	4BA-83560-01	E2	4YV-E3174-00	B6	3FN-E5371-00	B11	4YV-E8531-00	C2	2RN-F3157-00	C10
2VN-2582A-50	D10	4BA-83580-00	E2	4YV-E3178-00	B6	4YV-E5378-00	B12	4YV-E8535-00	C2	2RN-F3157-00	C10
4BA-2582U-00	D2	3WP-83890-00	E5	4YV-E3179-00	B6	4YV-E5379-00	B6	4YV-E8540-00	C2	4BA-F3173-00	C10
4BA-2582W-00	D5	3H3-83912-00	E5	4YV-E3226-00	B6	4YV-E5411-00	B12	4YV-E8542-00	C2	4BA-F3173-00	C11
4BA-2583V-00	D10	31A-83913-00	E5	4YV-E3228-00	B12	4YV-E5416-00	B6	4YV-F1110-10-98	C4	2RN-F3340-00-33	C11
34X-25845-00	D5	3GM-83922-00	E5	4YV-E3565-10	B9	4YV-E5421-00	B12	4YV-F1274-00	C4	21L-F3415-00	C9
4H7-25852-00	D7	3TJ-83940-02	B9	4YV-E3610-00	B9	4YV-E5431-00	B12	4BA-F1288-00	C4	4BA-F3435-00-98	C9
2GU-25852-50	D10	31A-83945-00	E5	4YV-E3625-00	B9	4YV-E5441-00	B9	4BA-F139W-00	C8	4BA-F3466-00	C9
380-25854-00	D10	4YV-83963-00	E5	4YV-E4101-10	B8	4YV-E5451-00	B12	4YV-F1418-00	C4	2RN-F3469-00	D6
4L0-25854-00	D7	4YV-83972-00	E5	4SB-E4103-00	B8	4YV-E5461-00	B12	4BA-F1441-00	D9	2RN-F414G-00	C13
2GU-25855-00	D10	4G1-84744-00	E2	4SB-E4104-00	B8	4YV-E6111-00	B13	2RN-F1518-00	D12	4BA-F4181-00	C12
2VN-25866-00	D10	3MA-85720-12	E7	4SB-E4115-00	B8	4YV-E6150-00	B13	4YV-F1578-R0	C5	4BA-F4182-00	C12
4L0-25867-00	D7	4YV-E1111-20	B2	4SB-E4133-00	B8	4YV-E6154-00	B13	4BA-F1611-00	C5	4BA-F4183-00	C12
2RJ-25870-00	D7	4YV-E1111-30	B2	4SB-E4134-00	B8	4YV-E6164-00	B13	5T8-F1639-00	C5	4BA-F4186-00	C12
4BA-25872-01	D7	4YV-E1193-00	B2	4SB-E4137-00	B8	2AH-E6324-00	B13	4BA-F1650-00	C5	2RN-F4188-00	C12
4BA-25873-01	D10	4YV-E1194-00	B2	5DU-E4197-00	B8	3NC-E6331-00	B13	4YV-F1668-00	C5	4BA-F4192-00	C12
31A-25894-01	D10	4YV-E1311-00	B2	4SB-E4216-00	B8	4YV-E6351-00	B13	4YV-F1668-20	C8	4BA-F4198-00	C6
4BA-25895-00	D10	4YV-E1311-10	B2	4SB-E4216-10	B8	4YV-E6356-00	B13	4BA-F1711-00-98	C6	4YV-F4231-R0	C12
3JD-25917-00	D2	4YV-E1351-00	B2	4SB-E4312-00	B8	4YV-E6357-00	B13	4BA-F1721-00-98	C6	3TH-F4256-00	C12
2KF-25919-10	D5	4YV-E1400-00	B3	4SB-E4325-00	B8	4YV-E6371-00	B13	4BA-F1751-00	C6	4BA-F4313-00	C12

CODIGO N.º	REF. NO.	CODIGO N.º	REF. NO.	CODIGO N.º	REF. NO.	CODIGO N.º	REF. NO.	CODIGO N.º	REF. NO.	CODIGO N.º	REF. NO.
4BA-F4718-00	C14	4BA-F8215-00	D11	4BA-H3333-00	D15	4BA-X835G-R0-TR	D11	90170-06010	E5	90201-10118	D7
4BA-F4728-00	C14	4YV-F8301-R0	D12	4BA-H3333-00	D15	4YV-X835K-40	D12	90170-06228	C3	90201-10118	D10
4BA-F4730-10	C14	4YV-F8303-R0	D12	4BA-H3333-00	D15	4YV-X835J-40	D12	90170-07856	C2	90201-106F2	D5
4BA-F4731-10	C14	4BA-F8321-10	D11	4BA-H3340-00	D15	90101-08846	D3	90170-10857	D14	90201-108L9	C2
2RN-F4741-00	C14	4BA-F833K-00	D12	4MJ-H3371-00	E7	90101-08873	B11	90170-10X03	D3	90201-108L9	C3
4BA-F4773-10-98	C14	4BA-F833M-00	D12	4BA-H3533-00	E2	90101-12676	C8	90170-12853	B3	90201-124E4	C8
4BA-F4776-00	C14	4BA-F833N-00	D12	4YV-H3550-00	E2	90101-12874	B11	90170-12854	B13	90201-12814	D15
4BA-F4785-00	C14	4BA-F835U-00	D11	4BA-H3611-00	E2	90105-08875	C4	90170-14855	B13	90201-128L1	B3
4BA-F478F-00	C14	4BA-F835V-00	D11	5T8-H3936-10	D7	90105-10634	D2	90171-14809	D3	90201-128L1	C3
2RN-F4796-00	C14	4BA-F835Y-00	D11	5T8-H3936-10	E7	90105-14060	C9	90176-07813	B2	90201-128M0	C3
2RN-F5149-00	C15	4BA-F836K-20	D12	5DU-H4112-00	E3	90109-06577	E5	90173-05523	D12	90201-128M1	C3
4BA-F5168-00-33	C15	2RN-F8371-00	D11	4BA-H4146-00	E3	90109-086F8	D8	90179-05523	D13	90201-148L6	B14
4BA-F5315-00	D3	2RN-F8372-00	D11	4BA-H4152-00	E3	90109-086F8	D9	90179-06403	C14	90201-158L5	B13
3PE-F5315-A0	C15	4BA-F8372-00	C6	4BA-H4152-10	E3	90109-100E8	D8	90179-08148	D6	90201-198L2	B6
4BA-F5338-00-33	D3	4BA-F8381-00	D11	5DU-H4197-00	E3	90110-05201	D11	90179-12248	B13	90201-208L7	B14
2RN-F5389-00	D3	4YV-F8390-R0	D11	5DU-H4300-00	E3	90110-05201	D12	90179-25X00	C9	90201-208L8	B14
2RN-F5412-00	D3	4YV-F8394-R0	D11	5DU-H4310-00	E3	90110-05806	C12	90183-04027	D11	90201-54X00	D3
4YV-F5446-10	D3	5DU-F839H-00	D12	4BA-H4312-00	E3	90110-05822	E7	90183-05024	D11	90202-05180	D11
2RN-F5846-00	C15	5DU-F839H-00	D12	5AD-H4314-00	E3	90110-06200	D12	90183-05024	D13	90202-05180	D12
2RN-F5862-00	D7	4YV-F839H-R0	D12	3WG-H4324-00	E3	90110-06X04	B4	90183-05042	D13	90202-05180	D13
4BA-F5875-10	D10	4YV-F839H-R0	D12	4BA-H4347-00	E3	90110-06X05	B12	90185-10037	D8	90202-05180	D13
4BA-F5876-00	D7	4YV-F839J-R0	D12	5DU-H4359-00	E3	90110-06X23	B4	90185-10091	C8	90202-05193	C12
4BA-F6121-20	D6	4YV-F839J-R0	D12	4BA-H4710-00	E4	90110-06X23	E6	90190-10833	C8	90205-04802	E6
4BA-F6122-20	D6	4YV-H1800-10	E6	4BA-H4714-00	E4	90110-08X00	C10	90201-05031	E2	90205-07801	C2
4BA-F6240-00	D6	4YV-H1910-00	E6	4BA-H4720-00	E4	90110-08X00	C11	90201-05031	E2	90208-17807	B13
2RN-F6241-00	D6	4YV-H1980-00	E6	4BA-H4721-00	E4	90110-08X00	D6	90201-058L4	B13	90209-10229	C8
2RN-F6246-00	D6	4BA-H2121-00	E2	4BA-H4724-00	E4	90111-08800	C3	90201-06008	B7	90215-12271	B13
4YV-F6260-10	D6	4BA-H2122-00	E6	4YV-H5111-00	C11	90113-14804	B13	90201-06055	D10	90240-08124	D10
4BA-F6280-00	D6	1TK-H2131-00	C4	4BA-H5130-00	E4	90116-07835	B11	90201-060A3	B5	90280-03805	B3
4BA-F6290-00	D6	4BA-H2131-00	E6	4BA-H5370-00	E6	90119-06044	C5	90201-060A3	E4	90282-04806	B3
4YV-F6331-00	B9	4BA-H2151-00	E6	4YV-H5500-00	D14	90119-06056	C6	90201-064H0	E3	90282-04807	B3
4YV-F6335-00	D6	4BA-H2155-00	E6	4YV-H5540-00	E6	90123-08046	D6	90201-06815	C8	90338-09800	D7
2RN-F639G-00	C6	2JW-H2370-00	E6	4SB-W0001-00	B9	90149-05244	D12	90201-06821	C5	90338-09800	E5
4BA-F7211-10	D8	4BA-H2530-00	E6	23L-W0041-00	D7	90149-05273	D11	90201-06X09	B4	90381-12805	C3
2RN-F7311-00-33	D8	3NC-H2540-00	E6	4BA-W0042-50	D10	90149-05299	D13	90201-07081	E2	90387-052M2	E2
4BA-F7315-00	D8	4YV-H2590-00	E6	3FY-W0045-00	D5	90149-06011	C12	90201-078L0	B2	90387-058P0	B12
4BA-F7413-00	D8	4BA-H3310-00	D15	3LD-W0045-10	D2	90149-06150	C14	90201-08083	D10	90387-060A7	E4
4BA-F7413-00	D8	4BA-H3311-00	D15	34X-W0047-00	D5	90149-06153	E5	90201-081E6	C10	90387-064H8	D9
4BA-F741L-10-98	D9	4BA-H3311-00	D15	3JD-W0047-00	D2	90149-06153	E5	90201-081E6	C11	90387-06500	C5
4BA-F742L-10-98	D9	4BA-H3311-00	D15	51L-W0048-00	D5	90149-08814	D2	90201-081E6	C11	90387-06553	C12
4BA-F7431-00	D9	4BA-H3311-00	D15	1UY-W0048-50	D2	90149-08814	D5	90201-083F7	B10	90387-065G0	C6
4BA-F7437-00	D9	4BA-H3312-00	D15	2KF-W0057-00	D5	90149-08814	D10	90201-08512	B4	90387-065J6	E3
4BA-F7441-00	D9	4BA-H3312-00	D15	3LD-W0057-00	D2	90154-06812	B12	90201-08512	B6	90387-067K6	D12
4BA-F7442-10-98	D8	4BA-H3312-00	D15	4BA-X1511-R0-TR	C5	90157-05079	D8	90201-08512	B6	90387-06869	C8
4BA-F7443-10-98	D8	4BA-H3312-00	D15	5DU-F1651-R0-TR	C6	90157-05079	D8	90201-086P8	C3	90387-06869	C8
4BA-F7451-00	D8	4BA-H3320-00	D15	5DU-X1731-20-TR	C6	90159-05028	C6	90201-088L3	B6	90387-07392	B5
4BA-F7461-00	D8	4BA-H3330-00	D15	5DU-X1741-20-TR	C6	90159-06084	C8	90201-088L3	B6	90387-084N8	D8
21L-F8100-10	C4	4BA-H3333-00	D15	4BA-X4110-00-3X	C12	90159-06816	C6	90201-088L3	B15	90387-084N8	D8
						90164-03027	E2	90201-08X01	B11	90387-08725	C3
								90201-08X01	B12		

CODIGO N.º	REF. NO.	CODIGO N.º	REF. NO.	CODIGO N.º	REF. NO.	CODIGO N.º	REF. NO.	CODIGO N.º	REF. NO.	CODIGO N.º	REF. NO.
90387-123N2	C15	90506-20843	D8	93101-12834	C3	93450-31114	C10	9582L-10030	D5		
90387-124H0	C8	90506-26833	D8	93101-15833	B13	93450-31114	C11	9582M-06020	E6		
90387-128E2	C8	90508-20572	D8	93101-17832	B3	93500-09827	C2	9582M-06020	C3		
90387-128P2	C3	90508-20572	D8	93101-24835	B3	93501-04011	C9	9582M-08012	C4		
90387-153N7	D3	90508-20846	B13	93102-20873	B14	93501-04011	D9	9582M-08035	B10		
90387-15765	D4	90508-28847	C3	93102-22826	D3	93503-16003	B13	9582M-10030	C11		
90387-168P1	B13	90560-12332	C15	93102-22858	D3	93560-15823	D3	9582N-06020	C5		
90401-10159	D7	90560-23219	D4	93103-10812	B4	93603-22028	B4	9700L-06016	B7		
90401-10159	D10	9131L-05010	C12	93105-45804	C15	93603-22028	B6	9700L-06030	E6		
90430-06166	B12	9131L-06020	B9	93106-20805	C15	93604-10X00	B4	9700M-05012	B5		
90430-09824	E6	9131L-06020	D6	93110-33023	C10	94561-91132	D3	9700M-06025	E5		
90430-12823	B11	9131L-06020	E6	93110-33023	C10	94681-91001	D3	97026-06025	D7		
90430-14822	B2	9131L-08030	C11	93210-088E1	B2	94701-00X00	B2	9730M-06020	C6		
90445-05773	B11	9131L-08035	C9	93210-12237	B15	9502L-06012	C5	9750M-06412	E7		
90445-093G9	C7	9131M-05014	B12	93210-12327	B4	9502M-06025	D7	9750M-06416	C8		
90445-10366	C12	9131N-04010	D14	93210-128E3	B12	95301-05600	E2	9750N-06516	E6		
90445-12718	B7	9131N-05012	B11	93210-138E4	B13	95301-05600	E2	97606-06120	C5		
90450-25823	B5	9131N-05016	B6	93210-15620	D10	95302-06600	E4	9760N-06212	C4		
90450-32X00	B9	9131N-05020	B12	93210-23858	C10	95307-05600	E2	97702-50022	E3		
90460-27815	B5	9131N-05020	B13	93210-23858	C11	9530L-08600	D3	9770L-50525	B7		
90464-13804	C12	9131N-05035	B6	93210-288E2	B10	9530M-06700	C3	9770M-40512	D11		
90464-13804	E6	9131N-06012	B4	93210-528E0	B2	9530M-06800	D11	9770M-40520	D11		
90465-08028	B6	9131N-06012	B15	93211-048D9	72	9530M-12700	D15	9770M-50614	D13		
90467-09006	C7	9131N-06040	B11	93306-20226	D3	95607-06100	E5	98502-06010	D9		
90467-09006	C12	9131N-06055	B4	93306-202X2	B3	95607-08200	C4	98503-03008	C12		
90467-09006	C12	91401-16012	D10	93306-203X6	B3	95607-12100	C8	98506-05040	E5		
90467-11044	D10	91401-20012	D9	93306-203YC	B14	95607-12200	C8	98506-05045	E5		
90467-11X01	C6	91401-25012	D8	93306-204X1	B14	9560M-06100	E5	98507-03012	E2		
90467-24140	B7	91401-25012	D9	93306-30101	C15	9570L-08500	D11	9850L-04006	E6		
90468-04817	B6	91404-30028	D3	93306-30202	D3	9570M-05500	D11	9850L-06016	D10		
90468-10050	D8	91701-06040	D9	93306-303Y7	B3	9570M-05500	E4	9850L-06020	D10		
90480-01141	C6	91701-08042	D8	93306-303Y7	B3	9570M-08500	B10	9850M-05035	E5		
90480-12014	C6	91701-08042	D8	93310-112X5	B3	9570N-05500	C14	98706-04012	D7		
90480-12014	C6	91809-08806	B12	93315-21429	B14	9570N-06500	C5	98707-03008	E5		
90480-12236	D11	91812-12805	B11	93315-21429	B14	9580L-06010	B9	9870M-06025	D11		
90480-13398	D12	92906-06600	D7	93315-31841	C8	9580L-06012	D12	98907-04010	B2		
90480-13428	E2	92907-03100	E2	93410-08130	B4	9580L-06012	D12	99001-10600	C3		
90480-14433	C6	92907-06300	E2	93410-14815	B14	9580L-06012	J12	99241-00080	C5		
90480-15363	B5	9290L-06100	D10	93410-20825	B14	9580M-06012	C4	99241-00080	C6		
90480-16284	B5	9290L-06100	D10	93410-20825	B14	9580M-06012	C9				
90480-18276	E4	9290L-10200	D8	93410-52821	D3	9580M-06016	C5				
90480-35394	D11	9290M-05100	B5	93430-08036	B6	9580M-06025	B5				
90501-10312	E5	9290M-05200	D8	93440-08130	B6	9580M-06016	C12				
90501-12743	D9	9290M-05200	D9	93440-08130	B6	9580N-06025	C12				
90501-12860	C2	9290M-06600	E5	93440-14815	B14	9581L-08020	D9				
90501-18801	C3	9290M-06600	B10	93440-18816	B14	9581L-08020	D9				
90501-20859	B13	9290N-06100	C9	93440-20825	B14	95821-06010	C14				
90508-18856	B10	9290N-06600	E6	93450-12816	B3	9582L-06020	D11				